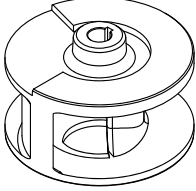

HYDROPOMPE	SINGLE CHANNEL IMPELLER	DN 100
FM SERIES		50 Hz
1024/22 - 1034/31 1054/55		4 POLE

USE

Submersible electric pumps particularly suitable for pumping industrial sewage, screened waste water and mud in the pumping stations. They can be used also to lift clear and dirty water and rain water.

MATERIALS

Motor housing

Cast iron EN GJL 250 (UNI EN 1561)

Pump housing

Cast iron EN GJL 250 (UNI EN 1561)

Bearing housing

Cast iron EN GJL 250 (UNI EN 1561)

Impeller

Cast iron EN GJS 400 (UNI EN 1563)

Mechanical seal motor side

Graphite/Ceramic

Mechanical seal impeller side

Silicon Carbide/Silicon Carbide (SiC/SiC)

Base frame

Stainless steel AISI 304

Motor shaft

Stainless steel AISI 420

Bolts and nuts

Stainless steel Grade A2

Cable

10 meters type H07RN-F

1024/22; 1034/31 with 7G1,5mm² cable

1054/55 with 7G2,5mm² cable

LIMITS TO USE

Max temperature of the liquid pumped

+40°C

pH of the liquid pumped

6÷10

Max immersion depth

20 m

Liquid density

1,0 kg/dm³

Min immersion depth for continuous service

517 mm

Free passage

80 mm

Max number starts/hour

20

Acoustic pressure level issued

<70dB(A)

MOTOR

The electric motor is asynchronous with squirrel cage rotor in dry chamber

Class of insulation F

Protection degree IP68

4pole; 50Hz

Main voltage values and relative tolerance in relation to the rated voltage value:

THREE-PHASE

400V ±10%

Other voltages on request.

OTHER FEATURES ON REQUEST

Frequency 60 Hz (*see specific catalogue*)

Other voltages

SECURITY

Thermal probes in the winding

Conductivity probe in the oil chamber

TECHNICAL DATA

MODEL	P1	P2		VOLTAGE V	CURRENT A	CABLE m	WEIGHT kg
	kW	kW	CV				
1024/22	2,8	2,2	3,0	400 (3~)	5,4	10	97
1034/31	3,9	3,1	4,2	400 (3~)	7,5	10	100
1054/55	6,6	5,5	7,5	400 (3~)	11,7	10	112

FM SERIES	1024/22 - 1034/31 1054/55		DN 100
			50 Hz
			4 POLE

PERFORMANCE RANGE

CAPACITY												
<i>l/s</i>	0	10	15	20	25	30	35	40	45	50	55	60
<i>m³/h</i>	0	36	54	72	90	108	126	144	162	180	198	216
<i>l/min</i>	0	600	900	1200	1500	1800	2100	2400	2700	3000	3300	3600

MODEL	CURVE N°	HEAD m											
		1024/22	1	10,6	8,4	7,3	6,3	5,1	3,9	2,6	-	-	-
1034/31	2	12,7	10,5	9,4	8,4	7,2	6,0	4,5	3,0	-	-	-	-
1054/55	3	19,0	15,2	13,8	12,5	11,3	10,2	9,1	7,8	6,5	4,8	3	-

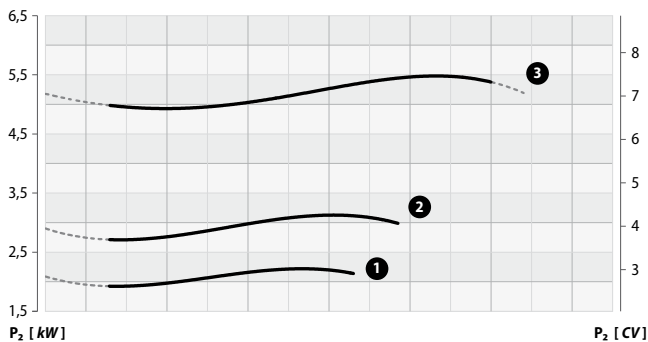
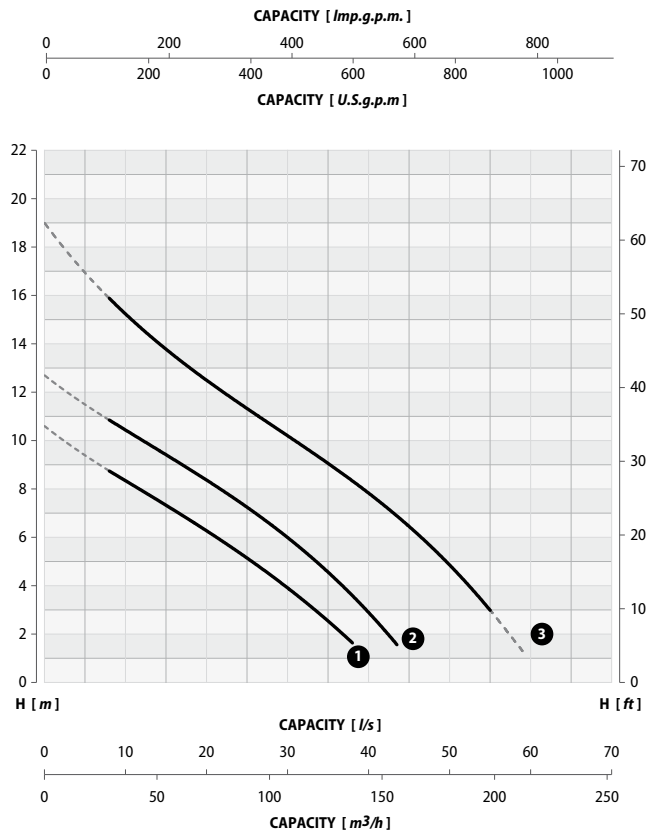

Performance tolerance in according to UNI/ISO 9906 Grade 3B

FM SERIES

**1024/22 - 1034/31
1054/55**



SINGLE CHANNEL IMPELLER

DN 100

50 Hz

4 POLE

INSTALLATION DIMENSIONS

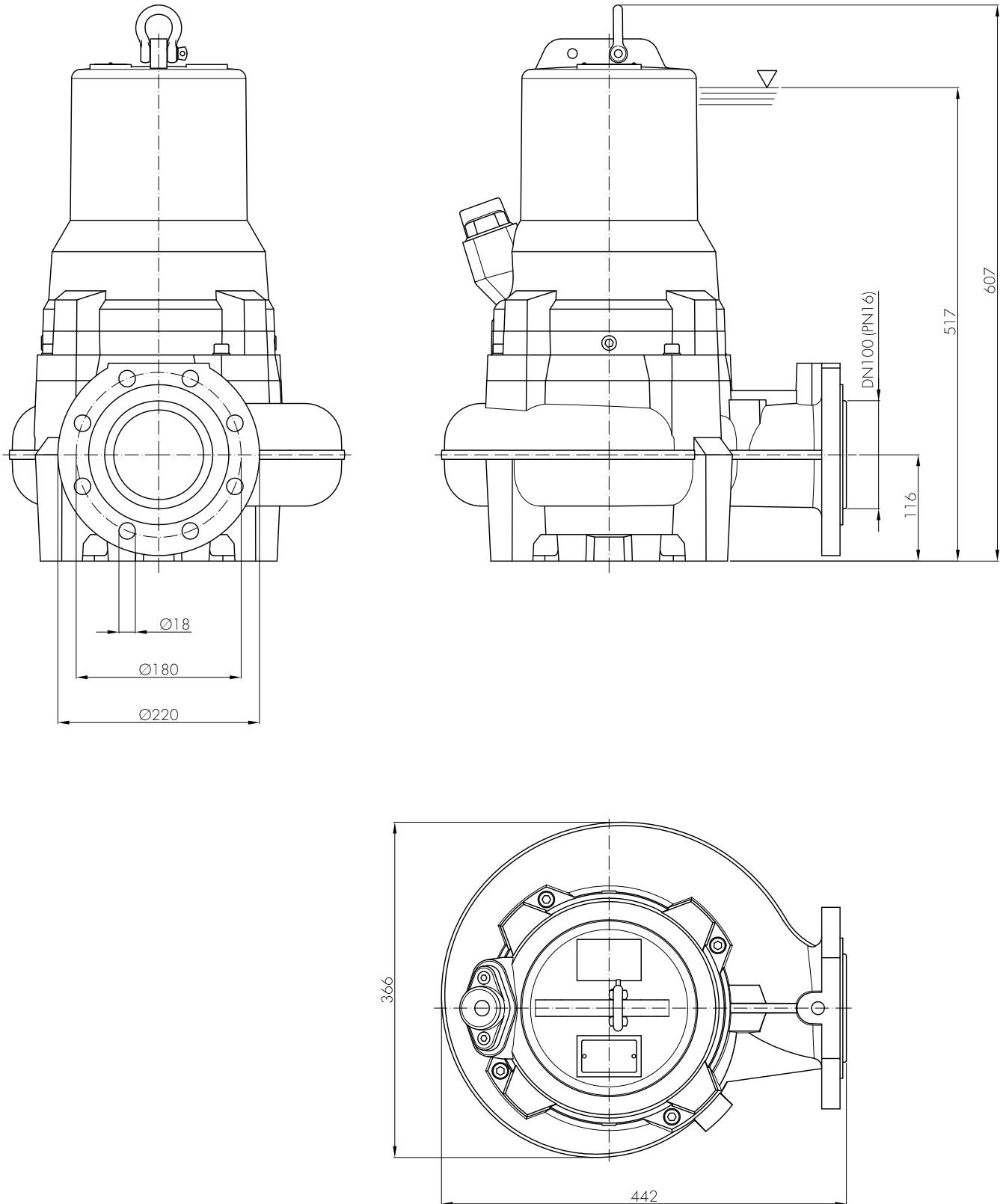

FM SERIES	1024/22 - 1034/31 1054/55	 SINGLE CHANNEL IMPELLER	DN 100
			50 Hz
			4 POLE

PERMANENT INSTALLATION WITH COUPLING SYSTEM

PORTABLE INSTALLATION

It is the recommended installation for the permanent pumping station. The electric pump is guided by two pipes and it is connected automatically to the coupling system. The quick connection ensures that the pump can be easily removed and re-installed.

Transportable as emergency pump with connection to the hose and for free installation in the well.

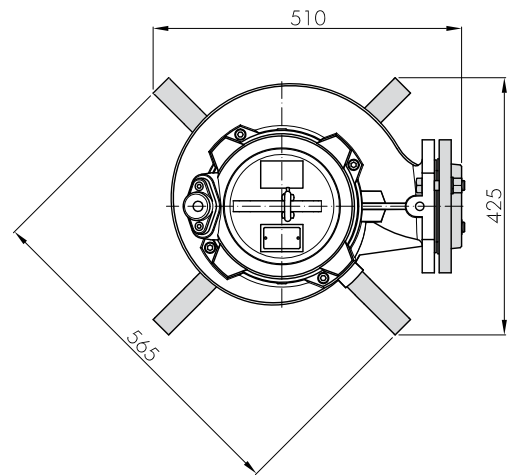
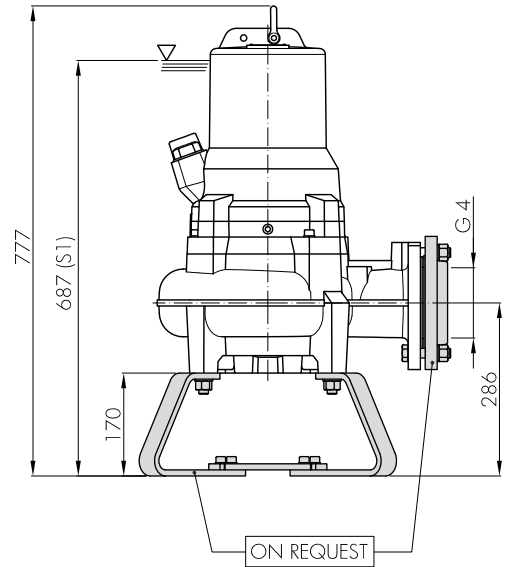
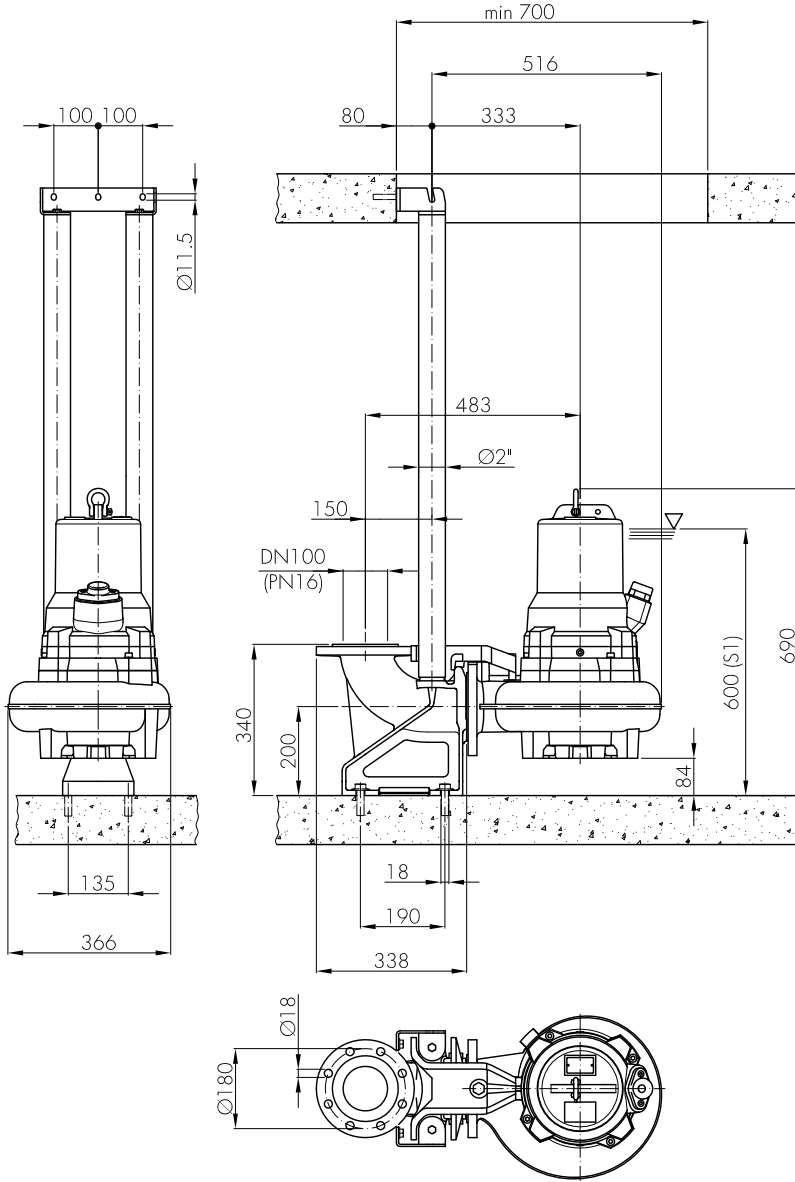

NOTES



.....

i Changes reserved

02/2019