



SUBMERSIBLE

PUMPS FOR DIRTY WATERS

with vortex impeller [VS] suitable for sludge and waste waters with suspended solids

POMPE

SOMMERSIBILI PER ACQUE SPORCHE

con girante vortex [VS] idonea per fanghi e acque di scarico con solidi sospesi

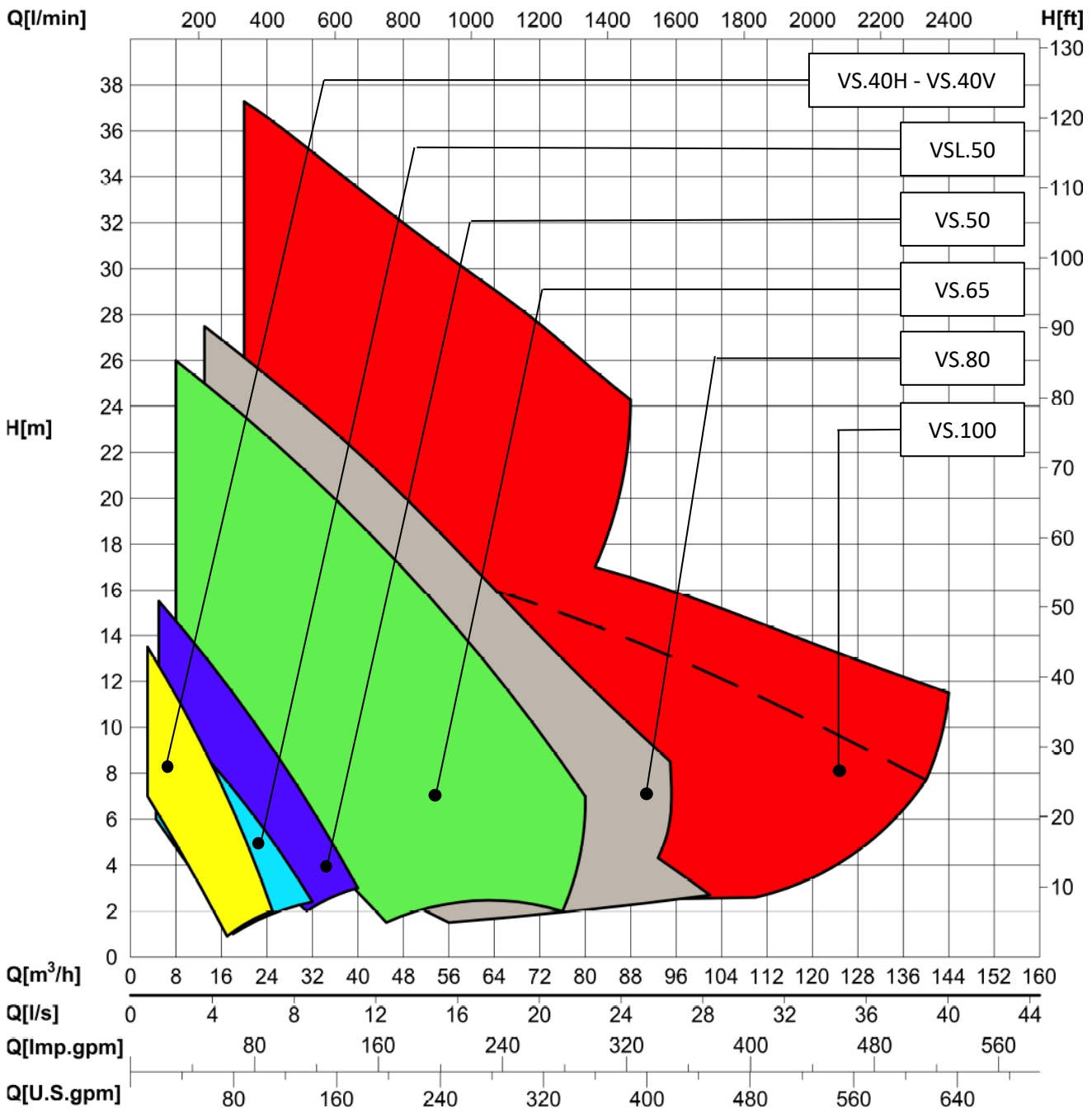

EN

Submersible pumps with a backward open impeller. Hydraulic solution that guarantees a wide free passage of solids reducing the risk of blocking and clogging of the impeller.

Very suitable to pump sewage and domestic/industrial waste waters.

- 1 Cast Iron G25 Motor Body.
Corpo motore in ghisa GG25.
- 2 Stator (1 ~ or 3 ~).
Statore avvolto (1 ~ or 3 ~).
- 3 Oil Chamber - cooling and lubrication of the mechanical seals.
Camera olio - raffreddamento e lubrificazione delle tenute meccaniche.
- 4 Mechanical seals.
Tenute meccaniche.
- 5 Impeller.
Girante .
- 6 GG25 Cast iron body pump.
Corpo Pompa in ghisa GG25.

Area of use / Settori d'impiego

- Waste water treatment - civil / industrial plants
Trattamento delle acque di scarico - impianti civili / industriali.
- Drainage and lifting in domestic and residential systems.
Drenaggio e sollevamento in impianti domestici e residenziali.

Types of installation - Tipi di installazione

S Transportable underwater
Trasportabile in immersione

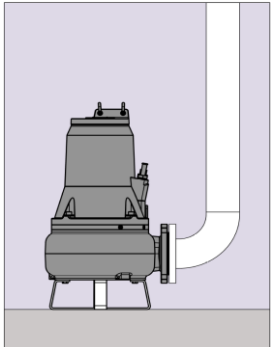

- Versatile solution suitable for various uses. A hose connection or connection flange is required for the rigid discharge line. The pump must be placed on a support stand.

- Soluzione versatile adatta a diversi impieghi. E' necessario un attacco per tubo flessibile o flangia di collegamento per la tubazione premente rigida. La pompa va posizioata su un cavalletto di sostegno.

IT

Elettropompe sommergibili con girante semiaperta arretrata. Soluzione idraulica che garantisce un ampio passaggio libero di corpi solidi, riducendo il pericolo di blocco della girante ed intasamento del corpo pompa.

Molto indicata per il pompaggio di reflui civili, reflui industriali ed acque luride in genere.

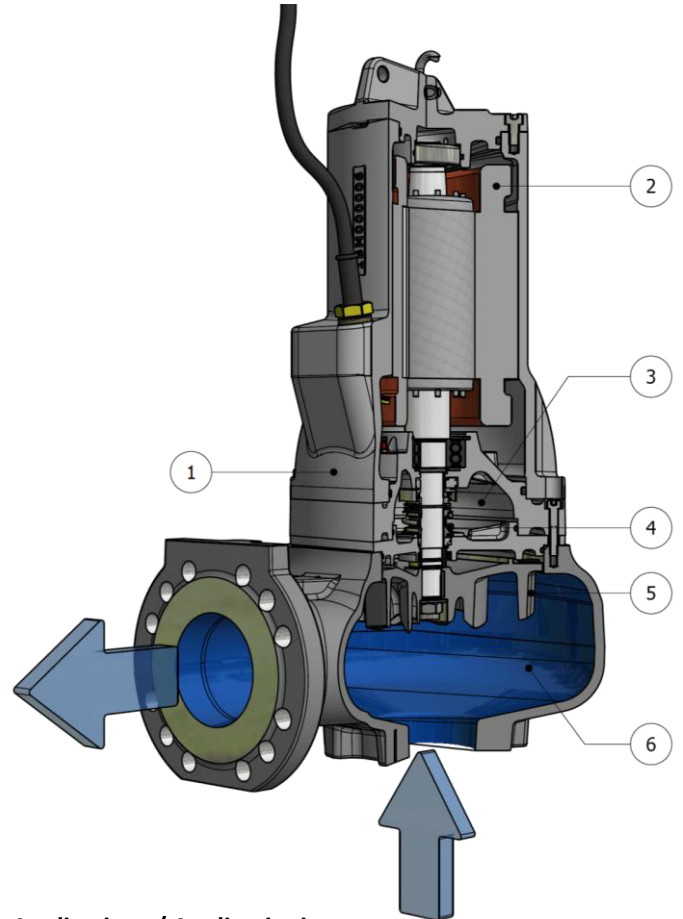

Applications / Applicazioni

- Water and sludge from civil, industrial, domestic and agricultural waste..
Acque e fanghi provenienti da scarichi civili, industriali, domestici ed agricoli.
- Drainage, rainwater and process water.
Acque di drenaggio, piovane e di processo.

FC Fixed submersible with coupling device
Fissa in immersione con dispositivi di accoppiamento

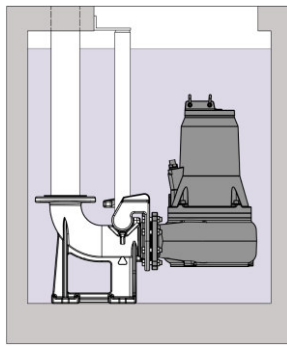

- Automatic positioning system of the pump inside the tank connected to the discharge pipe. The pump is lowered or extracted with a lifting chain; the pump slides along two guide rails until it engages with the foot coupling.

- Sistema di posizionamento automatico della pompa all'interno della vasca collegato alla tubazione premente. La pompa viene calata o estratta con catena di sollevamento; scorre lungo due tubi guida fino ad agganciarsi al piede di accoppiamento.

VS.40V_[GM.110L] series

THREE-PHASE MOTORS 3~

VS.40V_04.2T_[GM.110L] - 2 poles - 0,4 KW

SINGLE-PHASE MOTORS 1~

VS.40V_04.2M_[GM.110L] - 2 poles - 0,4 KW

VS.40V_04.2MA_[GM.110L] - 2 poles - 0,4 KW

VS.40V_[GM.110] series

THREE-PHASE MOTORS 3~

VS.40V_06.2T_[GM.110] - 2 poles - 0,6 KW

VS.40V_06.2TA_[GM.110] - 2 poles - 0,6 KW

VS.40V_09.2T_[GM.110] - 2 poles - 0,9 KW

VS.40V_09.2TA_[GM.110] - 2 poles - 0,9 KW

VS.40V_11.2T_[GM.110] - 2 poles - 1,1 KW

VS.40V_11.2TA_[GM.110] - 2 poles - 1,1 KW

SINGLE-PHASE MOTORS 1~

VS.40V_06.2M_[GM.110] - 2 poles - 0,6 KW

VS.40V_06.2MA_[GM.110] - 2 poles - 0,6 KW

VS.40V_09.2M_[GM.110] - 2 poles - 0,9 KW

VS.40V_09.2MA_[GM.110] - 2 poles - 0,9 KW

VS.40V_11.2M_[GM.110] - 2 poles - 1,1 KW

VS.40V_11.2MA_[GM.110] - 2 poles - 1,1 KW



VS.40V_[GM.110L]



VS.40V_[GM.110]

- Submersible pumps with vortex impeller, compact and robust construction.
- Pompe sommergibili con girante arretrata a vortice, compatte e di robusta costruzione.
- Pompes submersibles avec roue vortex, construction compacte et robuste.
- Bombas sumergibles con impulsor vortex, construcción compacta y robusta.
- Cast iron construction; base treatment with water-based acrylic primer and final finishing with water-based paint (30µm). Special coating with two-component epoxy resistant to abrasion on request (80µm).
- Costruzione in ghisa; trattamento di fondo con primer acrilico a base d'acqua e rifinitura finale con vernice a base d'acqua (30µm). Rivestimento speciale con bicomponente epossidico resistente all'abrasione (80µm) su richiesta.
- Construction en fonte ; traitement de base avec apprêt acrylique à base d'eau et finition finale avec peinture à base d'eau (30µm). Revêtement spécial avec époxy bicomposant résistant à l'abrasion (80µm) sur demande.
- Construcción de hierro fundido; tratamiento base con imprimación acrílica al agua y acabado final con barniz al agua (30µm). Revestimiento especial con epoxi bicomponente (80µm) resistente a la abrasión, bajo pedido.

OPERATING LIMITS - LIMITI DI UTILIZZO

- Tmax = 40 °C standard product
Tmax = 70 °C special version
6 ≤ PH ≤ 12
Chloride content < 200 mg/l
Abrasive solid content < 1mg/l
Density ~ 1 kg/dm³
Viscosity ~ 1 mm²/s;
- Tmax = 40 °C prodotto standard
Tmax = 70 °C versioni speciali
6 ≤ PH ≤ 12
Contenuto cloruri < 200 mg/l
Contenuto solidi abrasivi < 1mg/l
Densità ~ 1kg/dm³
Viscosità ~ 1mm²/s;
- Tmax = 40 °C produit standard
Tmax = 70 °C versions spéciales
6 ≤ PH ≤ 12
Teneur en chlorure < 200 mg/l
Teneur en solides abrasifs < 1mg/l
Densité ~ 1kg/dm³
Viscosité ~ 1mm²/s;
- Tmax = 40 °C producto estándar
Tmax = 70 °C versiones especiales
6 ≤ PH ≤ 12
Contenido de cloruro < 200 mg/l
Contenido sólidos abrasivos < 1mg/l
Densidad ~ 1kg/dm³
Viscosidad ~ 1mm²/s;

TECHNICAL DATA - DATI TECNICI

VS.40V_[GM.110L]

MODELS - MODELLI	VS.40V_04.2M	VS.40V_04.2MA	VS.40V_04.2T
RPM/Poles - NGiri al min/N° poli	3000 / 2	3000 / 2	3000 / 2
P2: Shaft power - Potenza all'albero [kW]	0,4	0,4	0,4
PI: Input Power - Potenza assorbita [kW]	0,59	0,59	0,59
Power Factor - Fattore di potenza [Cosφ]	0,95	0,95	0,89
Power supply/Freq - Alimentazione/Freq [V/Hz]	1 ~ 230 / 50	1 ~ 230 / 50	3 ~ 400 / 50
Single-phase - Monofase	•	•	
Three-phase - Triase			•
Starting - Avviamento	16 μF	16 μF	D.O.L.
Rated current - Corrente nominale [A]	3,5	3,5	1,2
Starting current - Corrente di spunto [A]	9,6	9,6	6
Free Passage - Passaggio libero Ø [mm]	32	32	32
Impeller diameter - Diametro girante [mm]	90	90	90
Floater level switch - Gallegggiante	-	•	-
Power cable type/length - Cavo alim tipo/lungh. [m]	H07RN-F 3G1,5 / 5		H07RN-F 4G1 / 5
Signal cable type/length - Cavo segn. tipo/lungh. [m]	-		-
N: Starts per hour - N: Avviamenti / ora	30	30	30
Pump weight - Peso pompa [kg]	15	15	15

VS.40V_[GM.110]

MODELS - MODELLI	VS.40V_06.2M	VS.40V_06.2MA	VS.40V_09.2M	VS.40V_09.2MA	VS.40V_11.2M	VS.40V_11.2MA	VS.40V_06.2T	VS.40V_06.2TA	VS.40V_09.2T	VS.40V_09.2TA	VS.40V_11.2T	VS.40V_11.2TA
RPM/Poles - NGiri al min/N° poli	3000 / 2	3000 / 2	3000 / 2	3000 / 2	3000 / 2	3000 / 2	3000 / 2	3000 / 2	3000 / 2	3000 / 2	3000 / 2	3000 / 2
P2: Shaft power - Potenza all'albero [kW]	0,6	0,9	1,1	1,1	1,48	1,48	0,6	0,9	1,18	1,18	1,47	1,47
PI: Input Power - Potenza assorbita [kW]	0,9	1,18	1,48	1,48	1,96	1,96	0,9	1,18	1,47	1,47	1,96	1,96
Power Factor - Fattore di potenza [Cosφ]	0,95	0,95	0,95	0,95	0,96	0,96	0,84	0,84	0,85	0,85	0,85	0,85
Power supply/Freq - Alimentazione/Freq [V/Hz]	1 ~ 230 / 50	1 ~ 230 / 50	1 ~ 230 / 50	1 ~ 230 / 50	1 ~ 230 / 50	1 ~ 230 / 50	3 ~ 400 / 50	3 ~ 400 / 50	3 ~ 400 / 50	3 ~ 400 / 50	3 ~ 400 / 50	3 ~ 400 / 50
Single-phase - Monofase	•	•	•	•	•	•						
Three-phase - Triase							•	•	•	•	•	•
Starting - Avviamento	20 μF	25 μF	25 μF	25 μF	25 μF	25 μF	D.O.L.	D.O.L.	D.O.L.	D.O.L.	D.O.L.	D.O.L.
Rated current - Corrente nominale [A]	4,5	6,5	7,7	7,7	7,7	7,7	1,6	2,0	2,0	2,0	2,8	2,8
Starting current - Corrente di spunto [A]	13,5	21	21,6	21,6	21,6	21,6	8,0	11	11	11	14	14
Free Passage - Passaggio libero Ø [mm]	40	40	40	40	40	40	40	40	40	40	40	40
Impeller diameter - Diametro girante [mm]	109	124	124	124	128	128	109	124	124	124	128	128
Floater level switch - Gallegggiante	-	•	-	•	-	•	-	•	-	•	-	•
Power cable type/length - Cavo alim tipo/lungh. [m]	H07RN-F 3G1,5 / 10						H07RN-F 4G1 / 10					
Signal cable type/length - Cavo segn. tipo/lungh. [m]	-						-					
N: Starts per hour - N: Avviamenti / ora	30	30	30	30	30	30	30	30	30	30	30	30
Pump weight - Peso pompa [kg]	23	24	24	24,5	24,5	24,5	23	24	24	24	24,5	24,5

Ⓐ = VS.40V_04.2T_[GM110L] / VS.40V_04.2M/MA_[GM110L]* - 0,4 kW

50 Hz Three-phase motors - 2 poles - 3000 rpm
 * 50 Hz Single-phase motors - 2 poles - 3000 rpm

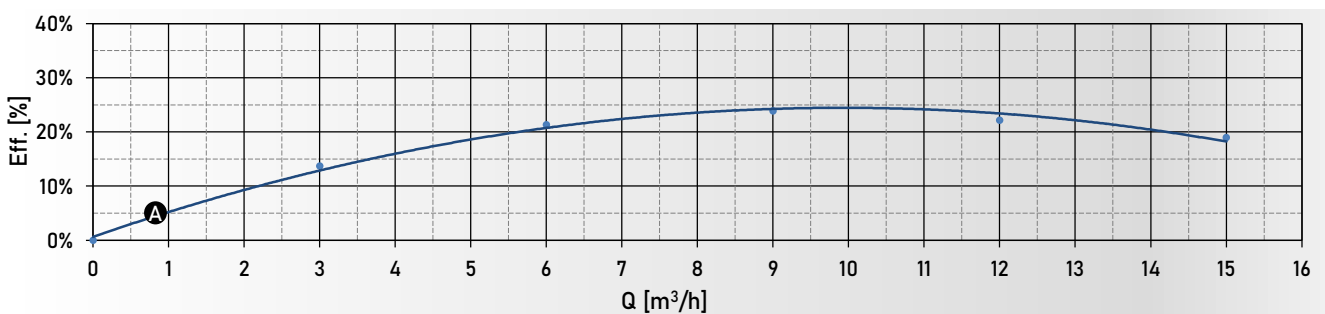
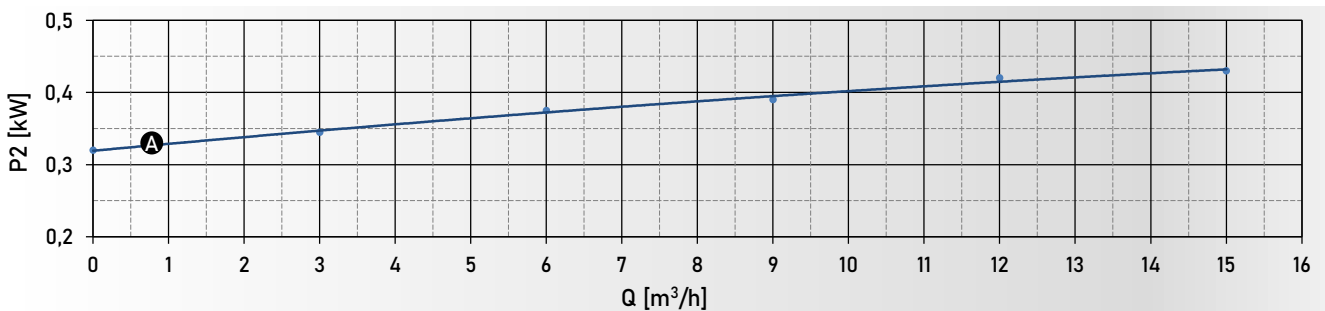
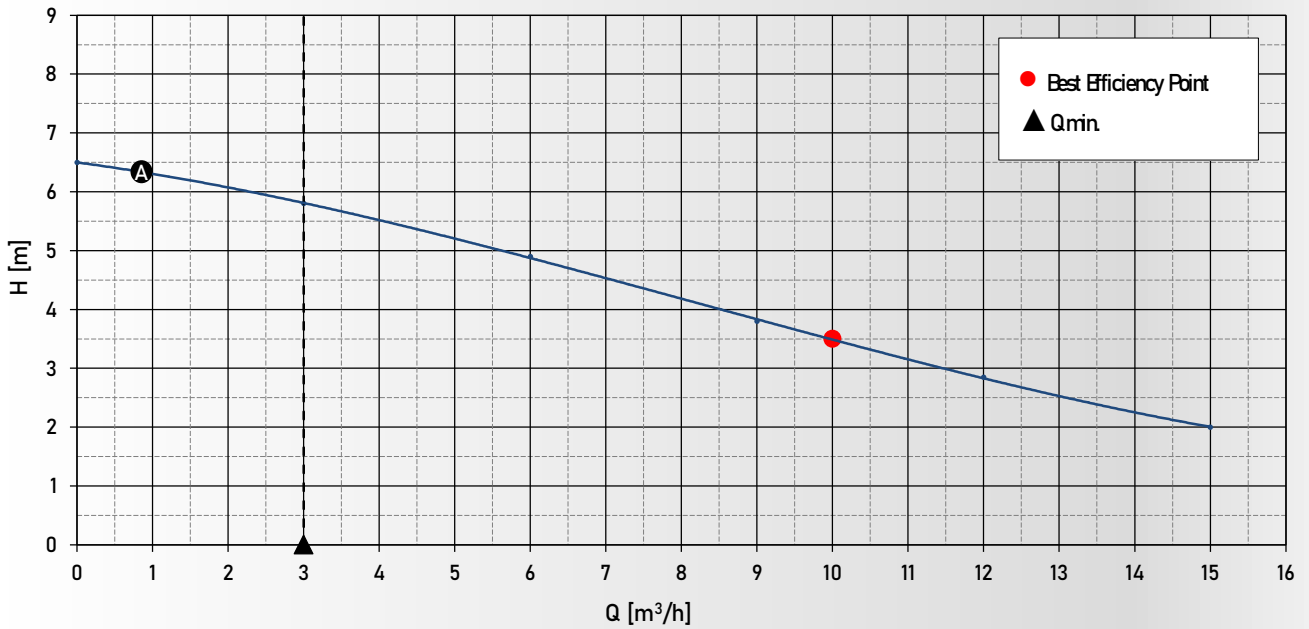

Q										
	m ³ /h	0	3	6	9	12	15	18	21	24
	L/min	0	50	100	150	200	250	300	350	400
	L/s	0	0,8	1,7	2,5	3,3	4,2	5,0	5,8	6,7

Ⓐ = VS.40V_04.2T/TA/M/MA 6,5 5,8 4,9 3,8 2,9 2,0

H [m]

- A** = VS.40V_06.2T/TA_[GM110]/VS.40V_06.2M/MA_[GM110]* - 0,6 kW
- B** = VS.40V_09.2T/TA_[GM110]/VS.40V_09.2M/MA_[GM110]* - 0,9 kW
- C** = VS.40V_11.2T/TA_[GM110]/VS.40V_11.2M/MA_[GM110]* - 1,1 kW

50 Hz Three-phase motors - 2 poles - 3000 rpm
 * 50 Hz Single-phase motors - 2 poles - 3000 rpm

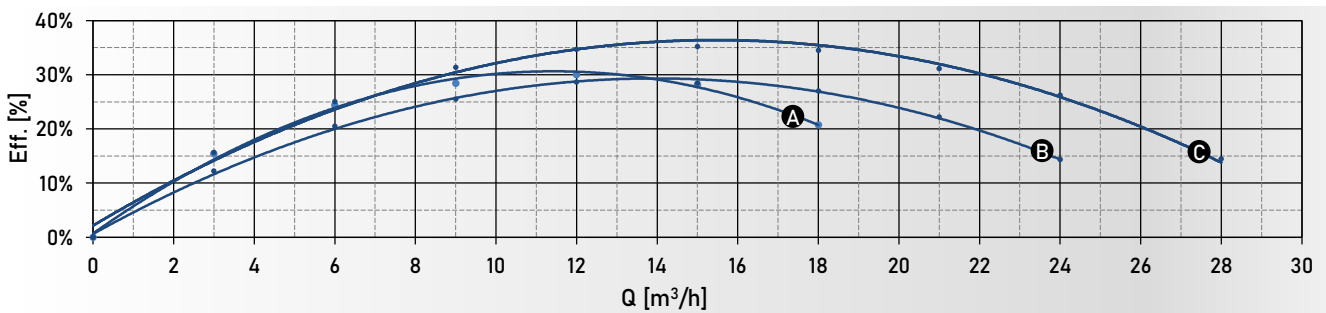
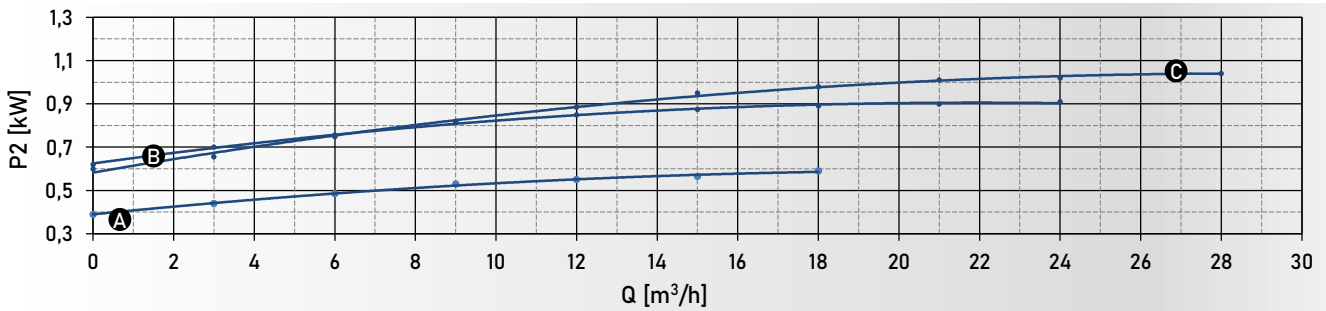
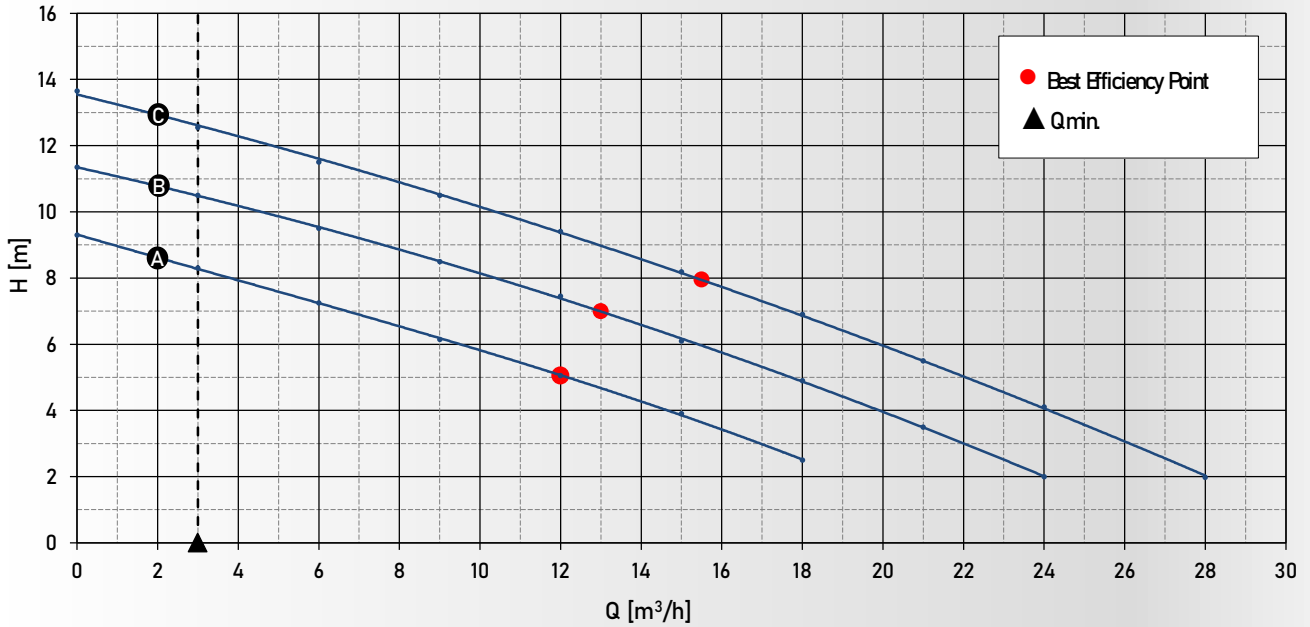

Q	m³/h	0	3	6	9	12	15	18	21	24	28
	L/min	0	50	100	150	200	250	300	350	400	467
	L/s	0	0,8	1,7	2,5	3,3	4,2	5,0	5,8	6,7	7,8

A	=VS.40V_06.2T/TA/M/MA	9,3	8,3	7,3	6,2	5,1	3,9	2,50			
B	=VS.40V_09.2T/TA/M/MA	11,4	10,5	9,5	8,5	7,45	6,10	4,90	3,50	2,00	
C	=VS.40V_11.2T/TA/M/MA	13,7	12,6	11,5	10,5	9,40	8,19	6,90	5,50	4,10	1,98

H [m]

SECTIONAL VIEWS - VISTE IN SEZIONE

VS.40V_[GM.110L]

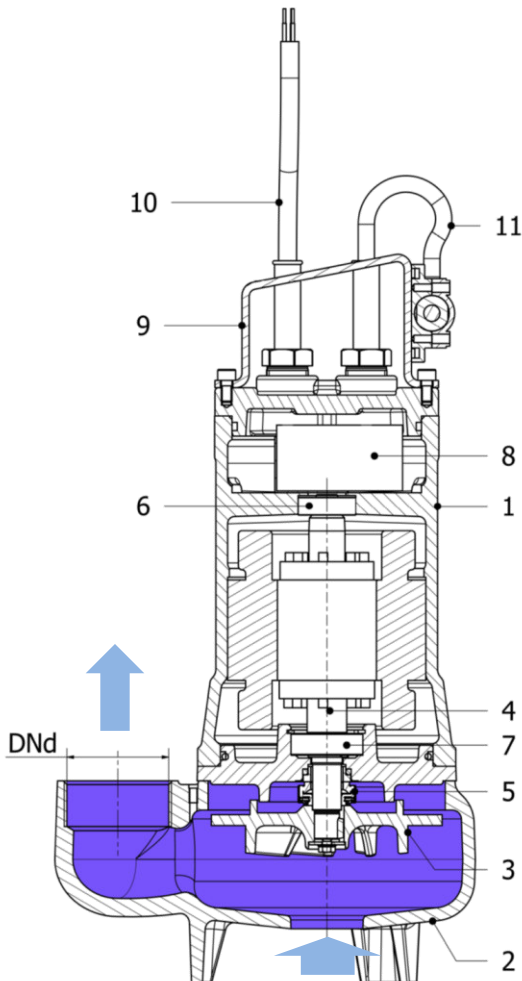

VS.40V_[GM.110]

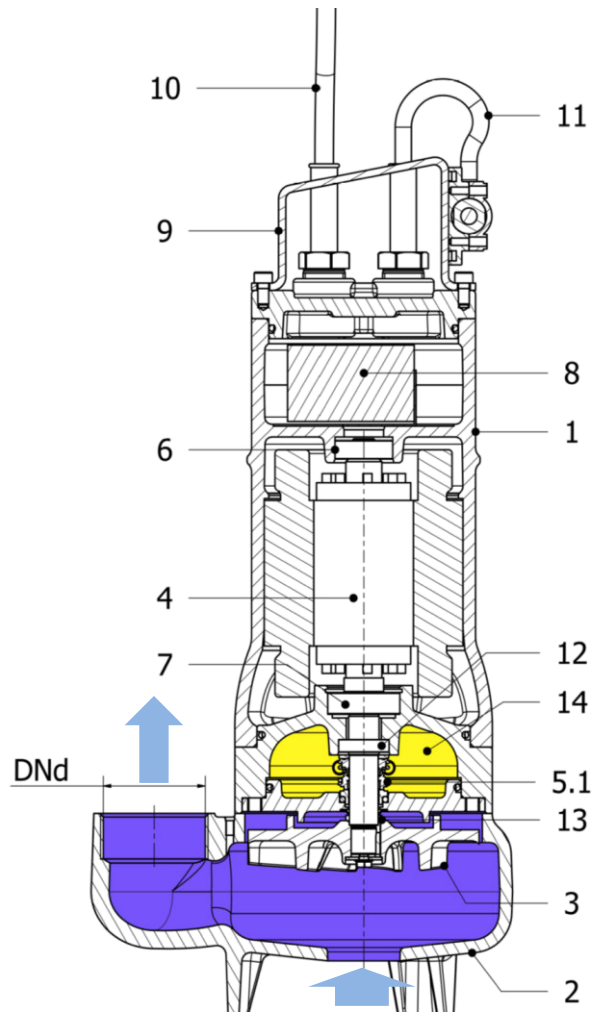

Pos.	Description	Descrizione	Material - Materiale
1	Motor body	Corpo motore	Cast Iron GG25 - Ghisa
2	Pump body	Corpo idraulico	Cast Iron GG25 - Ghisa
3	Impeller	Girante	Cast Iron GG25 - Ghisa
4	Shaft	Albero	Steel AISI 420B - Acciaio
5	Mechanical seal	Tenuta meccanica	Carbon graphite / Al-Oxide - NBR
5.1	Mechanical seal	Tenuta meccanica	Silicon carbide / Silicon Carbide
6	Upper bearing	Cuscinetto superiore	6201 2RS1
7	Lower bearing	Cuscinetto inferiore	6203-2RS1
8	Capacitor (M-MA models)	Condensatore (modelli M-MA)	
9	Handle	Maniglia	Galvanized steel - ferro zincato
10	Supply Cable	Cavo elettrico	H07RN-F
11	Float level switch (MA models)	Galleggiante (modelli TA-MA)	
12	Radial seal	Anello tenuta radiale	NBR
13	Seal V-ring	Anello tenuta V-ring	NBR
14	Oil chamber - cooling and lubrication of mechanical seal	Camera olio - raffreddamento e lubrificazione tenuta meccanica	
DNd	Delivery outlet Screw quality grade	Bocca di mandata Grado di qualità delle viti	Feamle G 2" - femmina A2

OVERALL DIMENSIONS - DIMENSIONI D'INGOMBRO

VS.40V_[GM.110L]

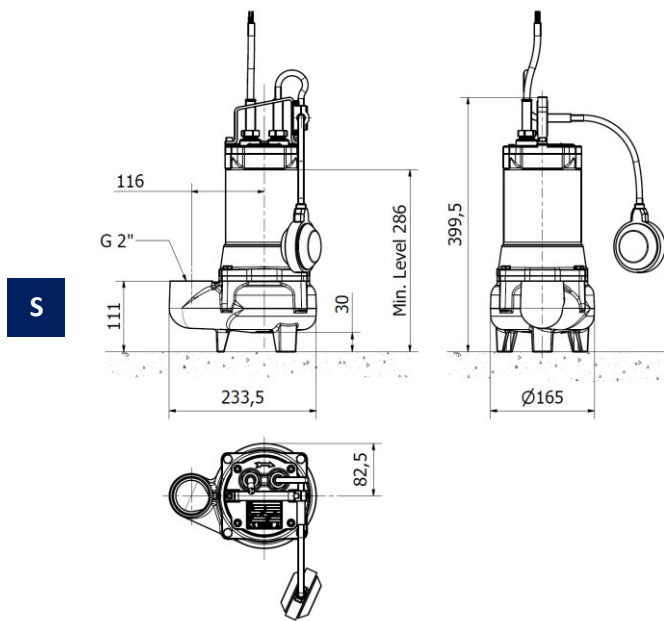

VS.40V_[GM.110]

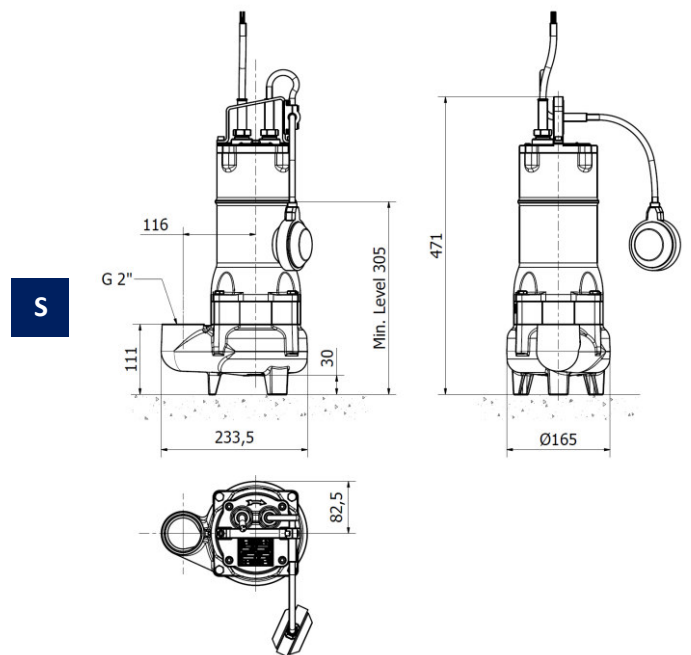

NOT AVAILABLE

NOT AVAILABLE

NON APPLICABILE

NON APPLICABILE

INSTALLATION MODES - MODALITA' D'INSTALLAZIONE

S = Transportable underwater - Trasporto in immersione

FC = Fixed with coupling device - Fissa con dispositivo di accoppiamento

PACKAGING DIMENSIONS - DIMENSIONI IMBALLAGGIO

	mm		
	A	B	C
Pump - Pompa	570	250	215
Foot coupling - Piede di accoppiamento	260	175	195

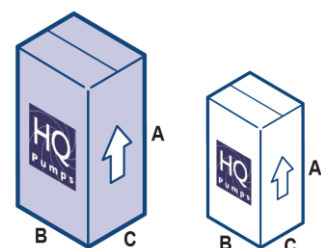

Dimensions and technical data are indicative, not binding and subjected to possible modifications without notice.
 Dimensioni e dati tecnici sono indicativi, non vincolanti e soggetti a eventuali modifiche senza preavviso.

ACCESSORIES - ACCESSORI



TBV - art. 4BV000003

Threaded valve G 2"
Valvola di ritegno filettata G 2"



SHELL - art. 3CS000021

Counterweight for level switch
Contrappeso per galleggiante



HF - art. 3CS000007

Level switch for sewage (10 m el. cable)
Regolatore di livello per acque reflue (cavo el. 10 m)



TUTOR - art. 3CS000020

Float guidance system for confined spaces
Sistema di guida del galleggiante per spazi ristretti



CHAIN - ART. 2SC000032

Stainless steel chain
Catena in acciaio inox



ECH



ECL

		P ₂ [KW]	In [A]	Avv. Start.
VS.40V_[GM.110L]				
VS.40V_04.2T_[GM.110L]	- 2 poles	0,4	1,2	DOL
VS.40V_04.2M/MA_[GM.110L]	- 2 poles	0,4	3,5	16µF
VS.40V_[GM.110]				
VS.40V_06.2.T/TA_[GM.110]	- 2 poles	0,6	1,6	DOL
VS.40V_09.2.T/TA_[GM.110]	- 2 poles	0,9	2,2	DOL
VS.40V_11.2.T/TA_[GM.110]	- 2 poles	1,1	2,9	DOL
VS.40V_06.2.M/MA_[GM.110]	- 2 poles	0,6	4,5	20µF
VS.40V_09.2.M/MA_[GM.110]	- 2 poles	0,9	7,0	25µF
VS.40V_11.2.M/MA_[GM.110]	- 2 poles	1,1	7,7	25µF

ECH - ELECTROMECHANICAL

1 Pump				2 Pumps			
ECH1.M-7	5EC000006	ECH1.M-14	5EC000008	ECH1.T-7	5EC000005	ECH2.M-7	5EC000030
				•			
•						•	
							•
				•			
							•
•						•	
	•						•
		•					•

ECL - ELECTRONIC

1 Pump		2 Pumps	
ECL1.M-16	5EC000081	ECL1.T-15	5EC000083
		•	
•			
			•
		•	
			•
•			
			•
•			
		•	
•			