



SUBMERSIBLE

PUMPS FOR DIRTY WATERS

with vortex impeller [VS] suitable for sludge and waste waters with suspended solids

POMPE

SOMMERSIBILI PER ACQUE SPORCHE

con girante vortex [VS] idonea per fanghi e acque di scarico con solidi sospesi

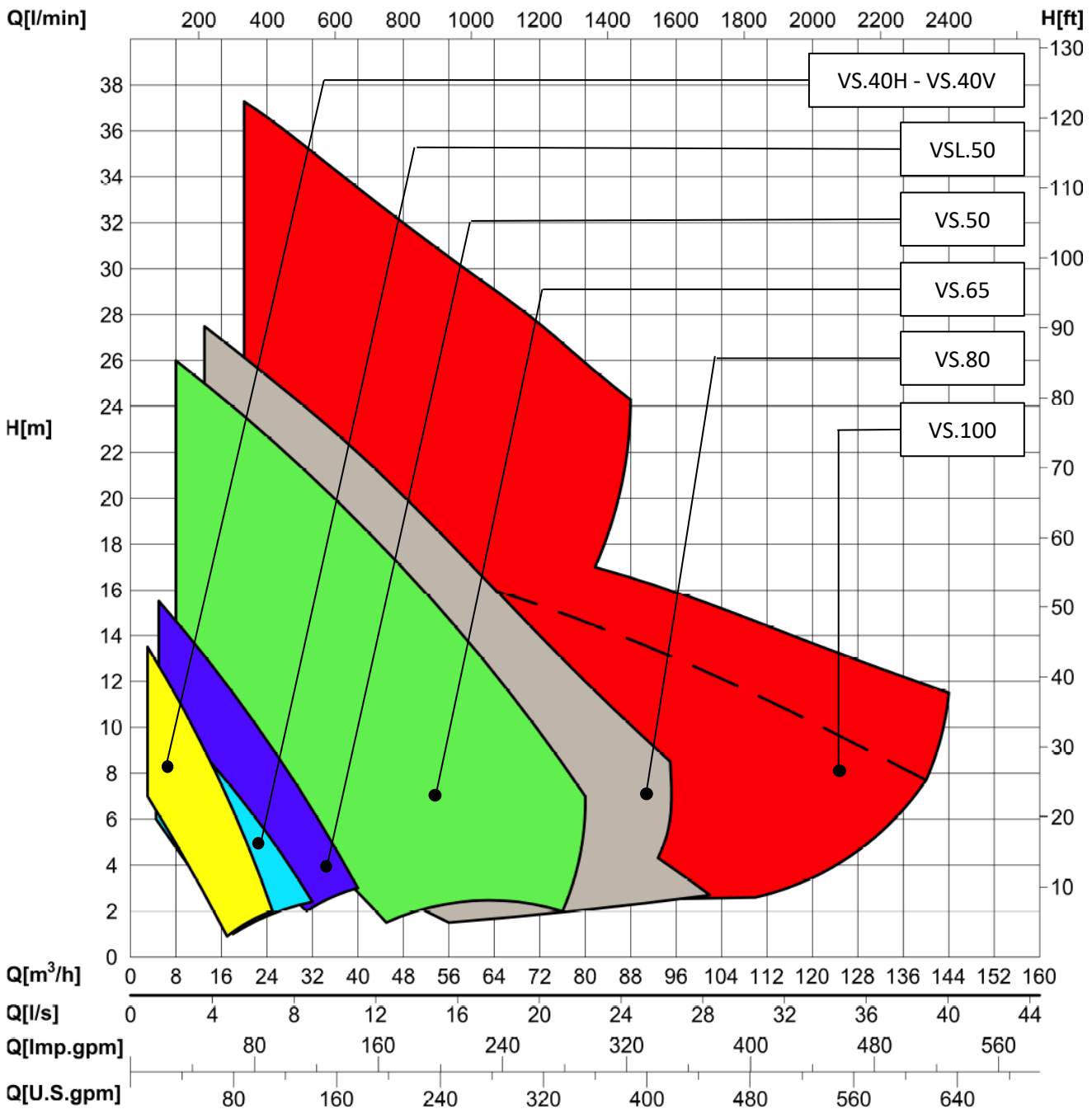

EN

Submersible pumps with a backward open impeller. Hydraulic solution that guarantees a wide free passage of solids reducing the risk of blocking and clogging of the impeller.

Very suitable to pump sewage and domestic/industrial waste waters.

- 1 Cast Iron G25 Motor Body.
Corpo motore in ghisa GG25.
- 2 Stator (1 ~ or 3 ~).
Statore avvolto (1 ~ or 3 ~).
- 3 Oil Chamber - cooling and lubrication of the mechanical seals.
Camera olio - raffreddamento e lubrificazione delle tenute meccaniche.
- 4 Mechanical seals.
Tenute meccaniche.
- 5 Impeller.
Girante .
- 6 GG25 Cast iron body pump.
Corpo Pompa in ghisa GG25.

Area of use / Settori d'impiego

- Waste water treatment - civil / industrial plants
Trattamento delle acque di scarico - impianti civili / industriali.
- Drainage and lifting in domestic and residential systems.
Drenaggio e sollevamento in impianti domestici e residenziali.

Types of installation - Tipi di installazione

S Transportable underwater
Trasportabile in immersione

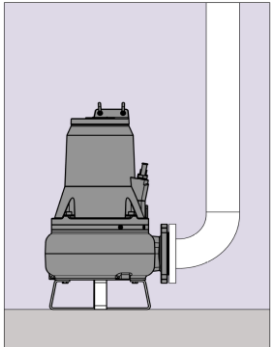

- Versatile solution suitable for various uses. A hose connection or connection flange is required for the rigid discharge line. The pump must be placed on a support stand.

- Soluzione versatile adatta a diversi impieghi. E' necessario un attacco per tubo flessibile o flangia di collegamento per la tubazione premente rigida. La pompa va posizioata su un cavalletto di sostegno.

IT

Elettropompe sommergibili con girante semiaperta arretrata. Soluzione idraulica che garantisce un ampio passaggio libero di corpi solidi, riducendo il pericolo di blocco della girante ed intasamento del corpo pompa.

Molto indicata per il pompaggio di reflui civili, reflui industriali ed acque luride in genere.

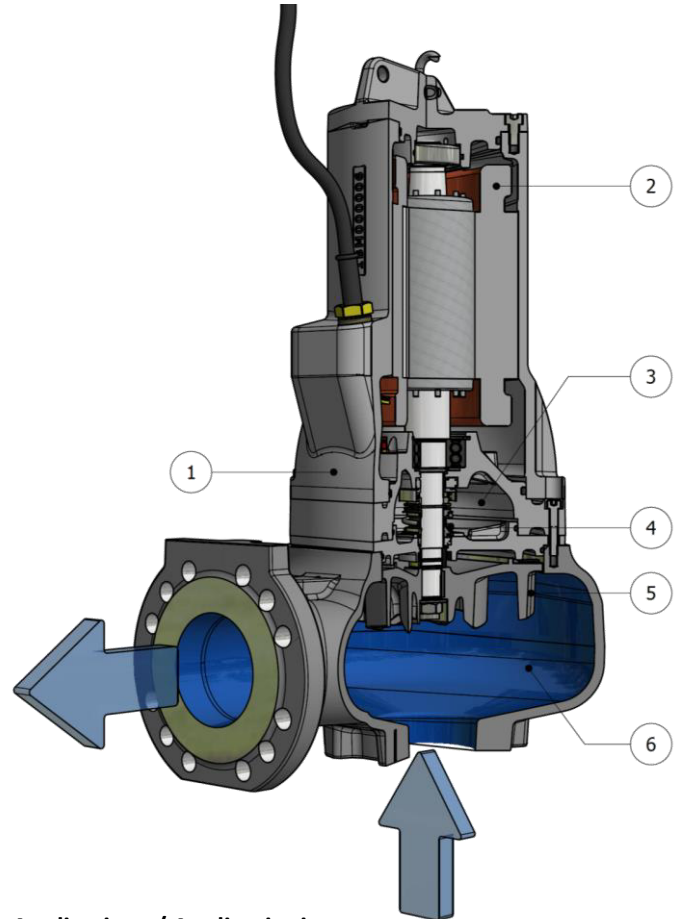

Applications / Applicazioni

- Water and sludge from civil, industrial, domestic and agricultural waste..
Acque e fanghi provenienti da scarichi civili, industriali, domestici ed agricoli.
- Drainage, rainwater and process water.
Acque di drenaggio, piovane e di processo.

FC Fixed submersible with coupling device
Fissa in immersione con dispositivi di accoppiamento

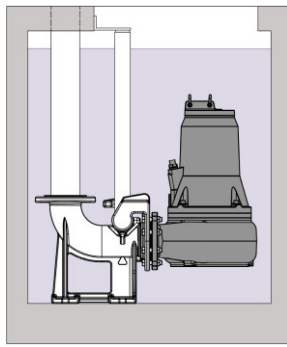

- Automatic positioning system of the pump inside the tank connected to the discharge pipe. The pump is lowered or extracted with a lifting chain; the pump slides along two guide rails until it engages with the foot coupling.

- Sistema di posizionamento automatico della pompa all'interno della vasca collegato alla tubazione premente. La pompa viene calata o estratta con catena di sollevamento; scorre lungo due tubi guida fino ad agganciarsi al piede di accoppiamento.

VS.100_[GM.173] series

THREE-PHASE MOTORS 3~

VS.100_30.4T_[GM.173]	- 4 poles	- 3,0 kW
VS.100_40.4T_[GM.173]	- 4 poles	- 4,0 kW

VS.100_37.2T_[GM.173]	- 2 poles	- 3,7 kW
VS.100_44.2T_[GM.173]	- 2 poles	- 4,4 kW
VS.100_55.2T_[GM.173]	- 2 poles	- 5,5 kW
VS.100_75.2T_[GM.173]	- 2 poles	- 7,5 kW

VS.100_[GM.200] series

THREE-PHASE MOTORS 3~

VS.100_55.4T_[GM.200]	- 4 poles	- 5,5 kW
VS.100_75.4T_[GM.200]	- 4 poles	- 7,5 kW

VS.100_90.2T_[GM.200]	- 2 poles	- 9,0 kW
-----------------------	-----------	----------

VS.100_[GM.240] series

THREE-PHASE MOTORS 3~

VS.100_90.4T_[GM.240]	- 4 poles	- 9,0 kW
-----------------------	-----------	----------

VS.100_110.2T_[GM.240]	- 2 poles	- 11 kW
VS.100_130.2T_[GM.240]	- 2 poles	- 13 kW
VS.100_150.2T_[GM.240]	- 2 poles	- 15 kW



VS.100_[GM.173]



VS.100_[GM.200] - VS.100_[GM.240]

- Pompe sommergibili con girante arretrata a vortice, compatte e di robusta costruzione.
- Submersible pumps with vortex impeller, compact and robust construction.
- Pompes submersibles avec roue vortex, construction compacte et robuste.
- Bombas sumergibles con impulsor vortex, construcción compacta y robusta.
- Costruzione in ghisa; trattamento di fondo con primer acrilico a base d'acqua e rifinitura finale con vernice a base d'acqua (30µm). Rivestimento speciale con bicomponente epossidico resistente all'abrasione (80µm) su richiesta.
- Cast iron construction; base treatment with water-based acrylic primer and final finishing with water-based paint (30µm). Special coating with two-component epoxy resistant to abrasion on request (80µm).
- Construction en fonte ; traitement de base avec apprêt acrylique à base d'eau et finition finale avec peinture à base d'eau (30µm). Revêtement spécial avec époxy bi-composant résistant à l'abrasion (80µm) sur demande.
- Construcción de hierro fundido; tratamiento base con imprimación acrílica al agua y acabado final con barniz al agua (30µm). Revestimiento especial con epoxy bicomponente (80µm) resistente a la abrasión, bajo pedido.

OPERATING LIMITS - LIMITI DI UTILIZZO

- Tmax = 40 °C prodotto standard
Tmax = 70 °C versioni speciali
6 ≤ PH ≤ 12
Contenuto cloruri < 200 mg/l
Contenuto solidi abrasivi < 1mg/l
Densità ~ 1kg/dm³
Viscosità ~ 1mm²/s;
- Tmax = 40 °C standard product
Tmax = 70 °C special version
6 ≤ PH ≤ 12
Chloride content < 200 mg/l
Abrasive solid content < 1mg/l
Density ~ 1 kg/dm³
Viscosity ~ 1 mm²/s;
- Tmax = 40 °C produit standard
Tmax = 70 °C versions spéciales
6 ≤ PH ≤ 12
Teneur en chlorure < 200 mg/l
Teneur en solides abrasifs < 1mg/l
Densité ~ 1kg/dm³
Viscosité ~ 1mm²/s;
- Tmax = 40 °C producto estándar
Tmax = 70 °C versiones especiales
6 ≤ PH ≤ 12
Contenido de cloruro < 200 mg/l
Contenido sólidos abrasivos < 1mg/l
Densidad ~ 1kg/dm³
Viscosidad ~ 1mm²/s;

TECHNICAL DATA - DATI TECNICI

VS.100_[GM.173]

MODELS - MODELLI

	VS.100_30.4T	VS.100_40.4T	VS.100_37.2T	VS.100_44.2T	VS.100_55.2T	VS.100_75.2T
RPM/Poles - NGiri al min / N° poli	1500 / 4	1500 / 4	3000 / 2	3000 / 2	3000 / 2	3000 / 2
P2: Shaft power - Potenza all'albero [kW]	3,0	4,0	3,7	4,4	5,5	7,5
PI: Input Power - Potenza assorbita [kW]	3,9	4,9	4,6	5,6	7,1	9,8
Power Factor - Fattore di potenza [Cosφ]	0,80	0,83	0,78	0,81	0,79	0,88
Power supply/Freq - Alimentazione/Freq [V/Hz]	3 ~ 400 / 50	3 ~ 400 / 50	3 ~ 400 / 50	3 ~ 400 / 50	3 ~ 400 / 50	3 ~ 400 / 50
Single-phase - Monofase						
Three-phase - Triase	•	•	•	•	•	•
Starting - Avviamento	D.O.L.	D.O.L.	D.O.L.	D.O.L.	D.O.L. / S.D.*	D.O.L. / S.D.*
Rated current - Corrente nominale [A]	7	8,5	8,5	10	12,9	16
Starting current - Corrente di spunto [A]	38	44,5	47	57	71 / 24	88 / 30
Free Passage - Passaggio libero Ø [mm]	85	85	97	97	97	
Impeller diameter - Diametro girante [mm]	203	220	154	161	174	189
Float level switch - Galleggianti	-	-	-	-	-	-
Power cable type/length - Cavo alim tipo/lungh. [m]			H07RN-F 4G2,5 / 10			
Signal cable type/length - Cavo segn. tipo/lungh. [m]			+ H07RN-F 4G1,5 / 10			
N: Starts per hour - N: Avviamenti / ora	25	20	20	20	20	15
Pump weight - Peso pompa [kg]	108	110	100	105	108	112

VS.100_[GM.200]

VS.100_[GM.240]

MODELS - MODELLI

	VS.100_55.4T	VS.100_75.4T	VS.100_90.2T	VS.100_90.4T	VS.100_110.2T	VS.100_130.2T	VS.100_150.2T
RPM/Poles - NGiri al min / N° poli	1500 / 4	1500 / 4	3000 / 2	1500 / 4	3000 / 2	3000 / 2	3000 / 2
P2: Shaft power - Potenza all'albero [kW]	5,5	7,5	9,0	9,0	11,0	13,0	15,0
PI: Input Power - Potenza assorbita [kW]	7,1	8,5	10,4	9,9	13,5	17	19
Power Factor - Fattore di potenza [Cosφ]	0,78	0,82	0,79	0,78	0,85	0,8	0,9
Power supply/Freq - Alimentazione/Freq [V/Hz]	3 ~ 400 / 50	3 ~ 400 / 50	3 ~ 400 / 50	3 ~ 400 / 50	3 ~ 400 / 50	3 ~ 400 / 50	3 ~ 400 / 50
Single-phase - Monofase							
Three-phase - Triase	•	•	•	•	•	•	•
Starting - Avviamento	S.D.	S.D.	S.D.	S.D.	S.D.	S.D.	S.D.
Rated current - Corrente nominale [A]	13	15	19	18,5	23,0	29	32
Starting current - Corrente di spunto [A] - DQL	72 *	83 *	143 *	102 *	126,5 *	159,0 *	176,5 *
Free Passage - Passaggio libero Ø [mm]	100	100	80	100	80	80	80
Impeller diameter - Diametro girante [mm]	220	233	180	242	188	195	205
Float level switch - Galleggianti	-	-	-	-	-	-	-
Power cable type/length - Cavo alim tipo/lungh. [m]		H07RN-F 7G2,5 / 10			2x H07RN-F 4G4 / 10		
Signal cable type/length - Cavo segn. tipo/lungh. [m]		+ H07RN-F 4G1,5 / 10			+ H07RN-F 4G1,5 / 10		
N: Starts per hour - N: Avviamenti / ora	20	15	15	15	10	10	10
Pump weight - Peso pompa [kg]	84	80	80	80	80	86	86

* Star-delta starting current is 1/3 of Direct on-line starting current / Corrente di spunto avviamento star-delta è 1/3 della corrente di spunto con avviamento diretto

- Ⓐ = VS100_30.4T_[GM173] - 3,0 kW
- Ⓑ = VS100_40.4T_[GM173] - 4,0 kW

50 Hz Three-phase motors - 4 poles - 1500 rpm

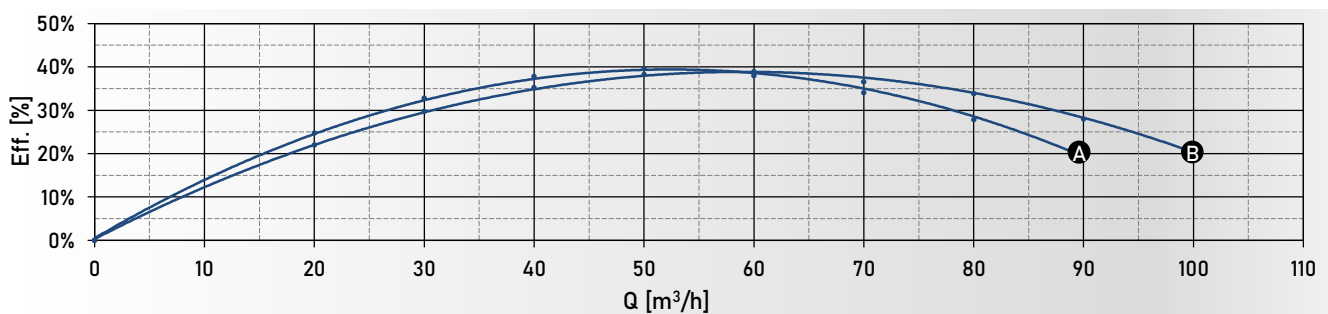
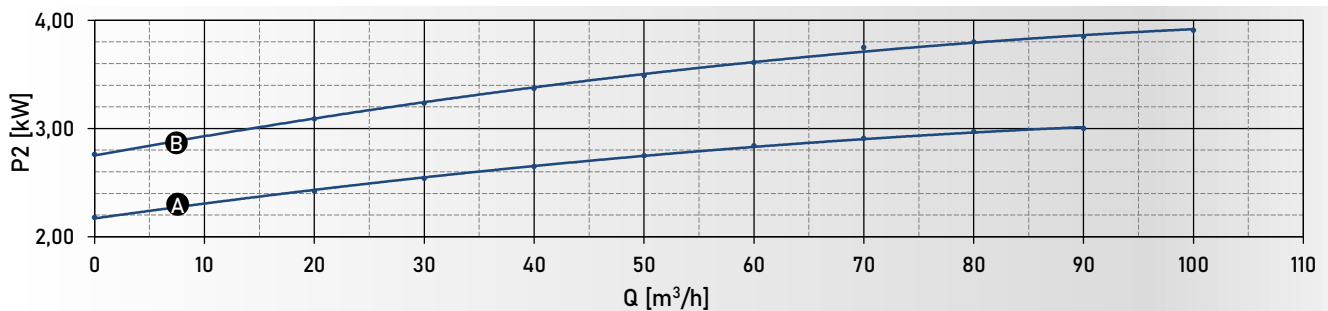
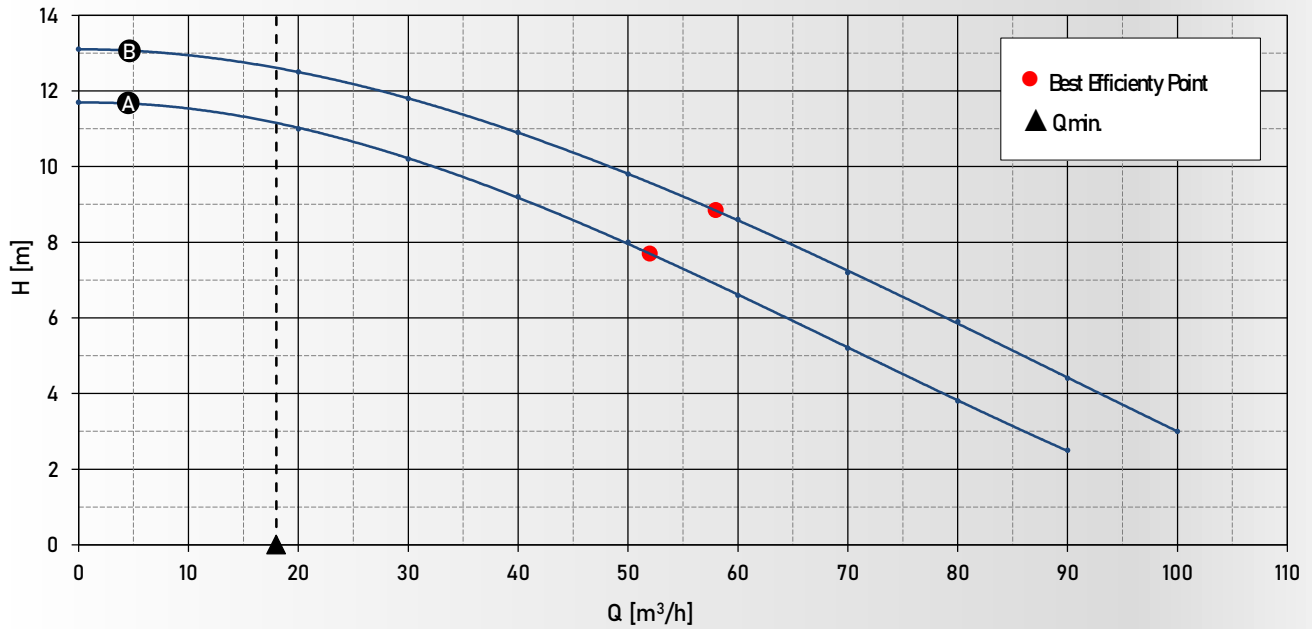

Q											
	m³/h	0	20	30	40	50	60	70	80	90	100
	L/min	0	333	500	667	833	1000	1167	1333	1500	1667
	L/s	0	5,6	8,3	11,1	13,9	16,7	19,4	22,2	25,0	27,8

Ⓐ = VS100_30.4T_[GM173]	11,7	11,0	10,2	9,2	8,0	6,6	5,2	3,8	2,5	
Ⓑ = VS100_40.4T_[GM173]	13,1	12,5	11,8	10,9	9,8	8,6	7,2	5,9	4,4	3,0

H [m]

- A** = VS100_60.4T_[GM200] - 6,0 kW
- B** = VS100_75.4T_[GM200] - 7,5 kW
- C** = VS100_90.4T_[GM240] - 9,0 kW

50 Hz Three-phase motors - 4 poles - 1500 rpm

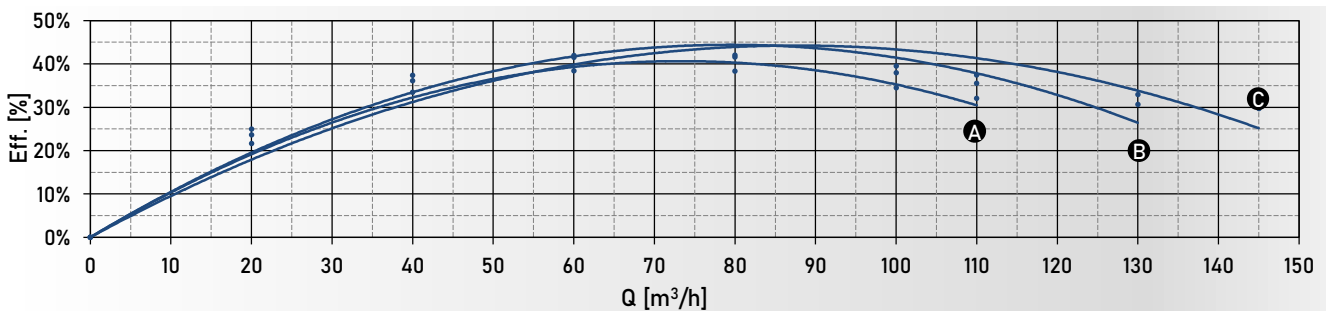
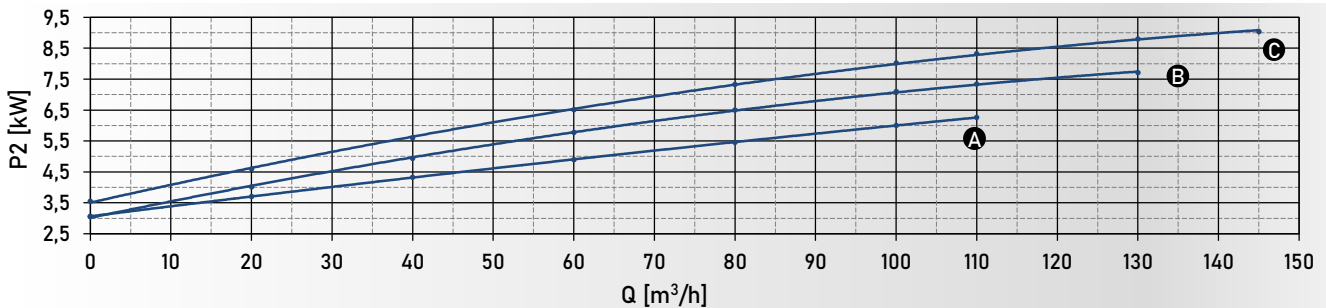
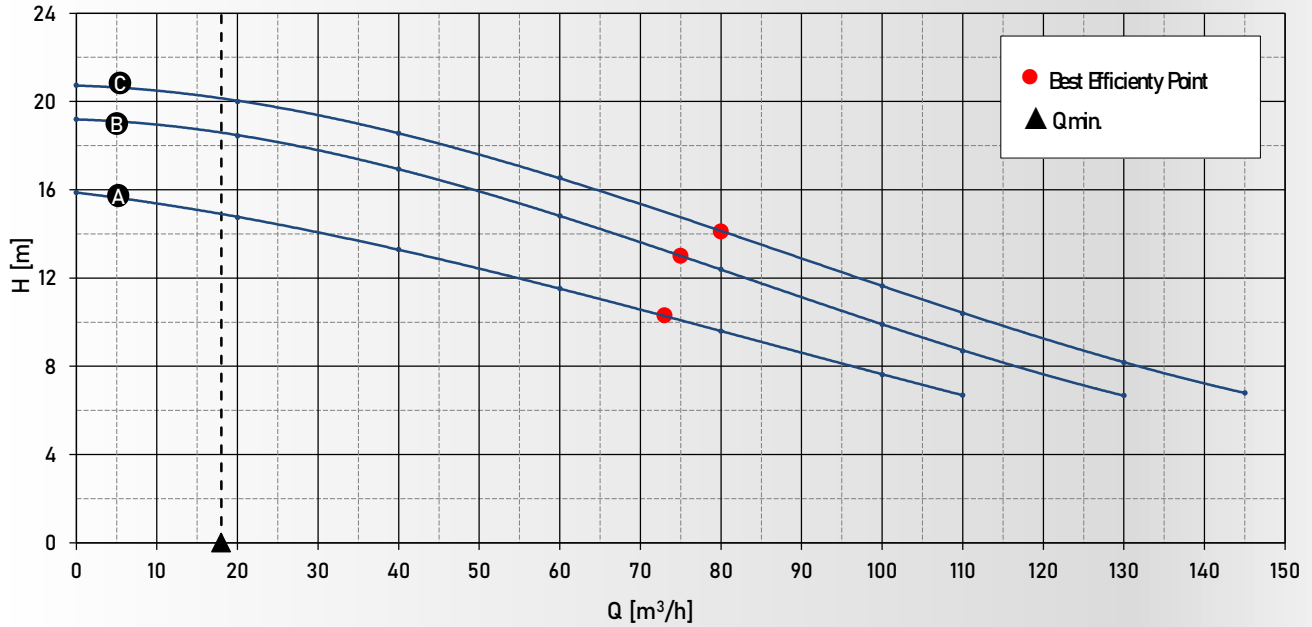

Q										
	m³/h	0	20	40	60	80	100	110	130	145
	L/min	0	333	667	1000	1333	1667	1833	2167	2417
L/s	0	5,6	11,1	16,7	22,2	27,8	30,6	36,1	40,3	

A = VS100_60.4T_[GM200]	15,9	14,8	13,3	11,5	9,6	7,6	6,7		
B = VS100_75.4T_[GM200]	19,2	18,5	16,9	14,8	12,4	9,9	8,7	6,7	
C = VS100_90.4T_[GM240]	20,7	20,0	18,6	16,5	14,2	11,6	10,4	8,2	6,8

H [m]

- A** = VS100_37.2T_[GM173] - 3,7 kW
- B** = VS100_44.2T_[GM173] - 4,4 kW
- C** = VS100_55.2T_[GM173] - 5,5 kW
- D** = VS100_75.2T_[GM173] - 7,5 kW

50 Hz Three-phase motors - 2 poles - 3000 rpm

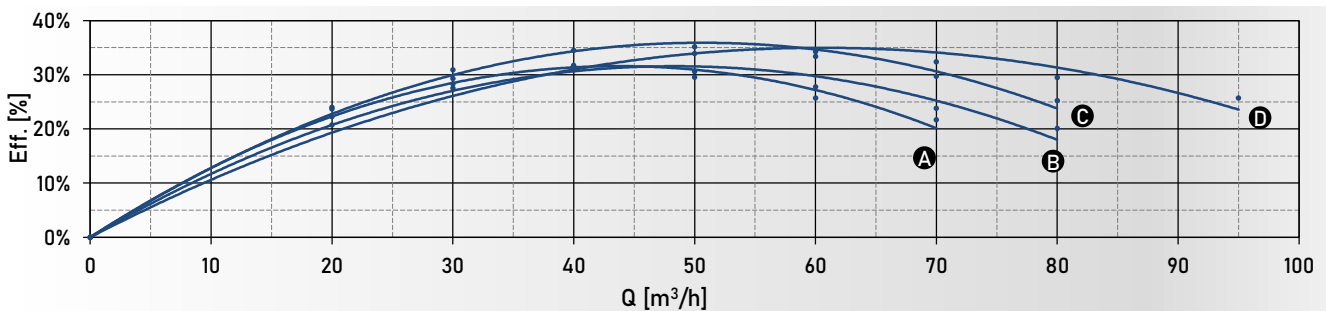
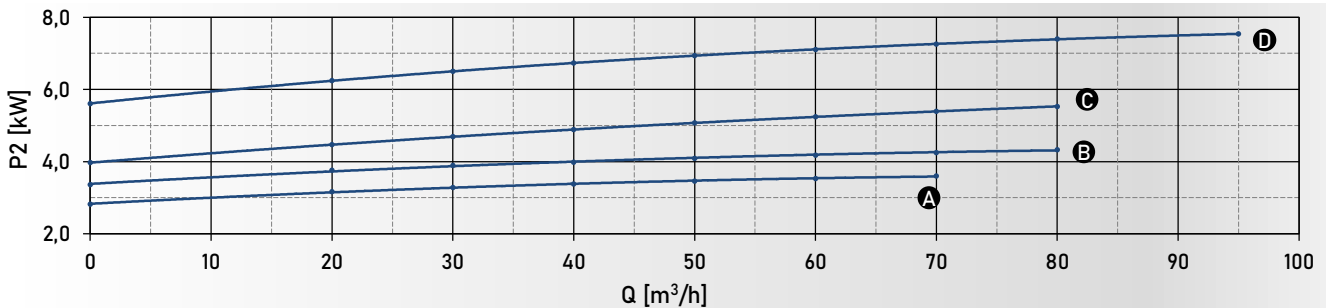
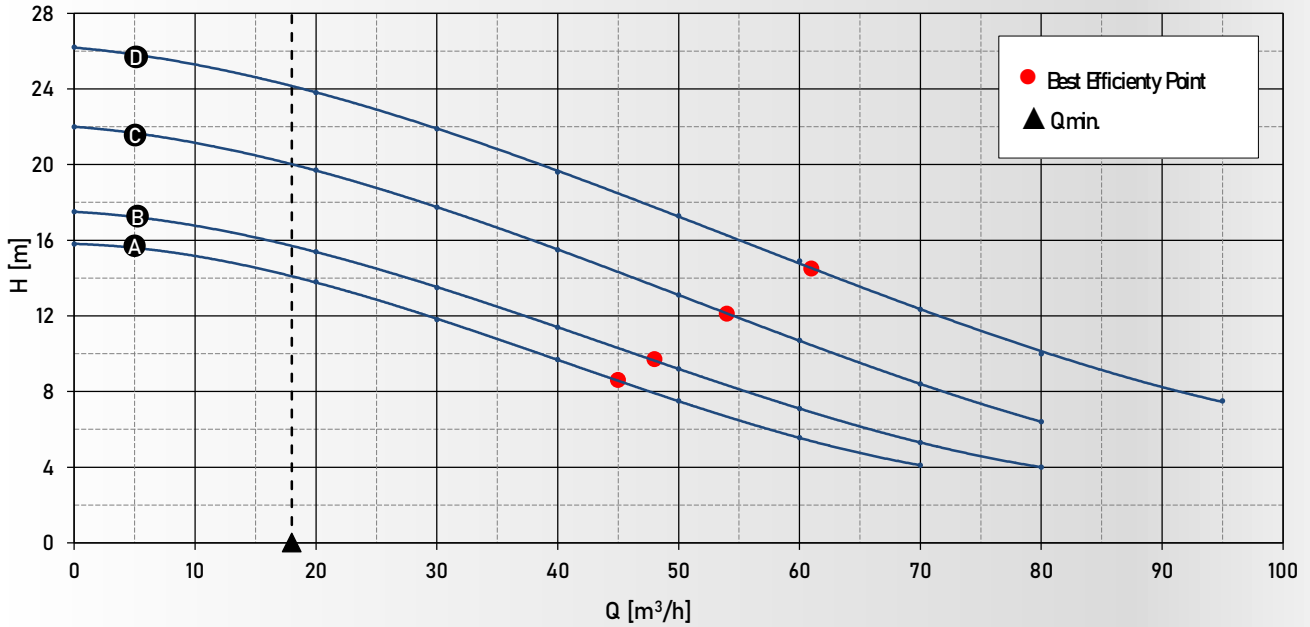

Q										
	m³/h	0	20	30	40	50	60	70	80	95
	L/min	0	333	500	667	833	1000	1167	1333	1583
L/s	0	5,6	8,3	11,1	13,9	16,7	19,4	22,2	26,4	

	0	20	30	40	50	60	70	80	95
A = VS100_37.2T_[GM173]	15,8	13,8	11,8	9,7	7,5	5,6	4,1		
B = VS100_44.2T_[GM173]	17,5	15,4	13,5	11,4	9,2	7,1	5,3	4,0	
C = VS100_55.2T_[GM173]	22,0	19,7	17,7	15,5	13,1	10,7	8,4	6,4	
D = VS100_75.2T_[GM173]	26,2	23,8	21,9	19,6	17,3	14,9	12,3	10,0	7,5

H [m]

- A** = VS.100_90.2T_[GM200] - 9,0 kW
- B** = VS.100_110.2T_[GM240] - 11,0 kW
- C** = VS.100_130.2T_[GM240] - 13,0 kW
- D** = VS.100_150.2T_[GM240] - 15,0 kW

50 Hz Three-phase motors - 2 poles - 3000 rpm

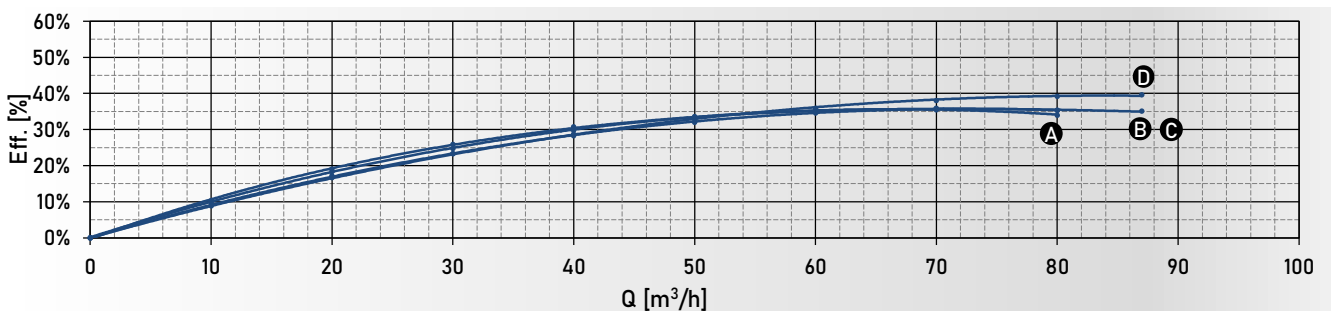
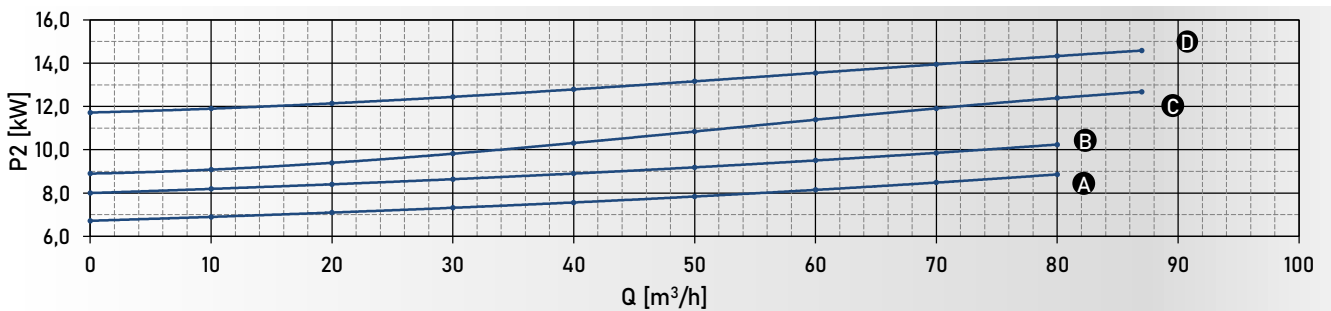
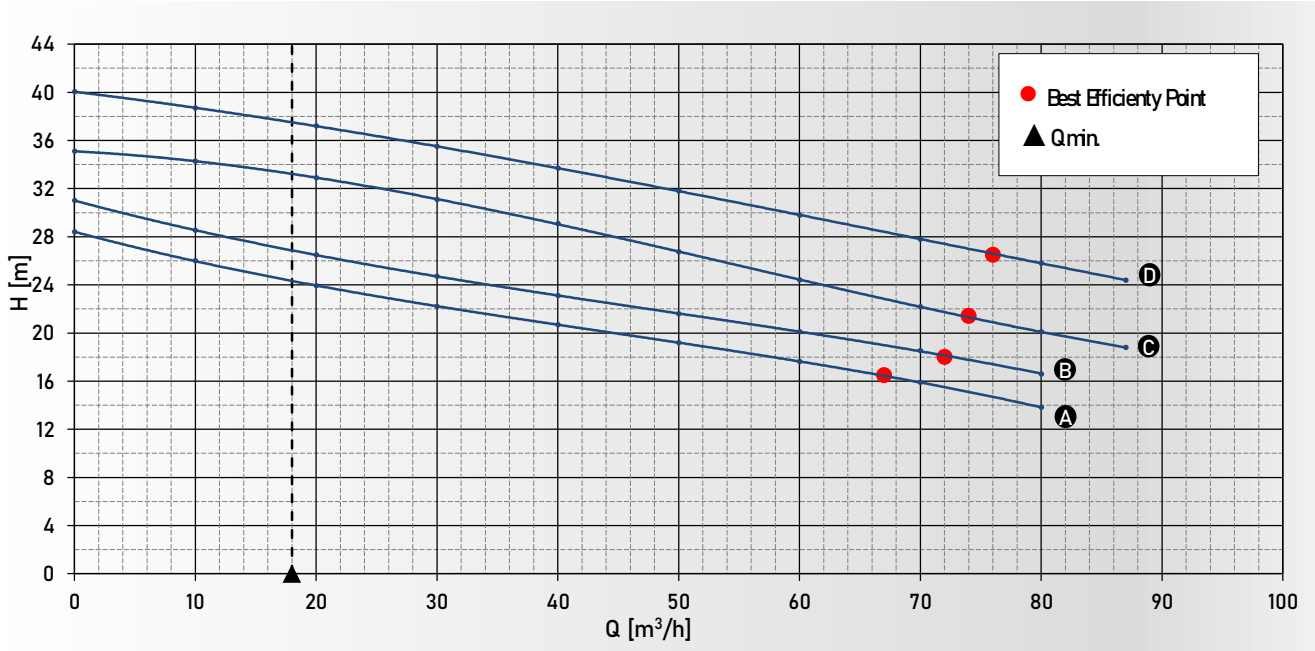

Q	m ³ /h	0	10	20	30	40	50	60	70	80	87
	L/min	0	167	333	500	667	833	1000	1167	1333	1450
	L/s	0	2,8	5,6	8,3	11,1	13,9	16,7	19,4	22,2	24,2

A = VS.100_90.2T_[GM200]	28,4	26,0	24,0	22,2	20,7	19,2	17,6	15,9	13,8	
B = VS.100_110.2T_[GM240]	31,0	28,6	26,5	24,7	23,1	21,6	20,1	18,6	16,6	
C = VS.100_130.2T_[GM240]	35,1	34,3	32,9	31,1	29,1	26,8	24,4	22,2	20,1	18,8
D = VS.100_150.2T_[GM240]	40,1	38,7	37,2	35,5	33,7	31,8	29,8	27,8	25,8	24,4

H [m]

SECTIONAL VIEWS - VISTE IN SEZIONE

VS.100_[GM.173]

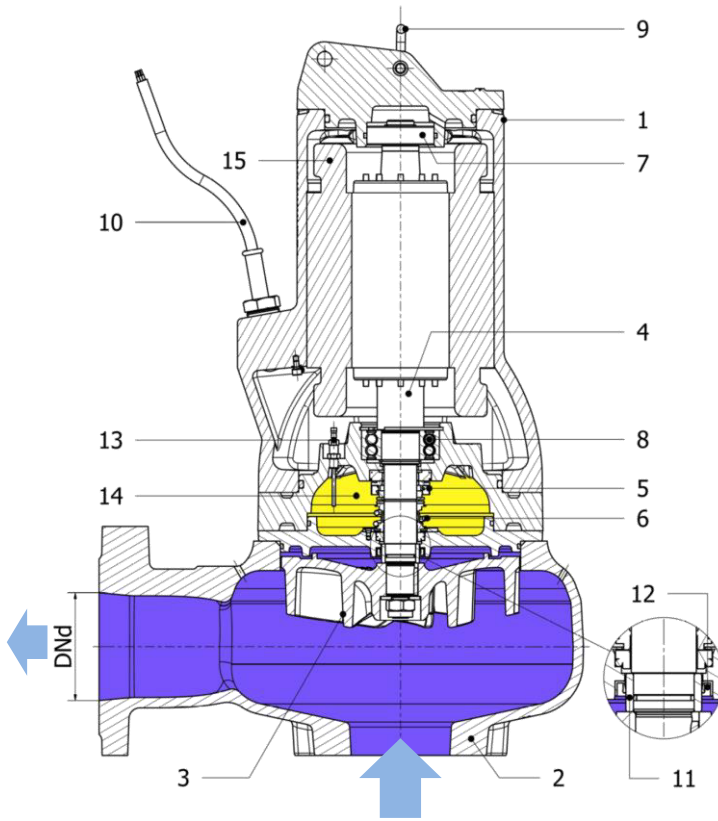

VS.100_[GM.200] - VS.100_[GM.240]

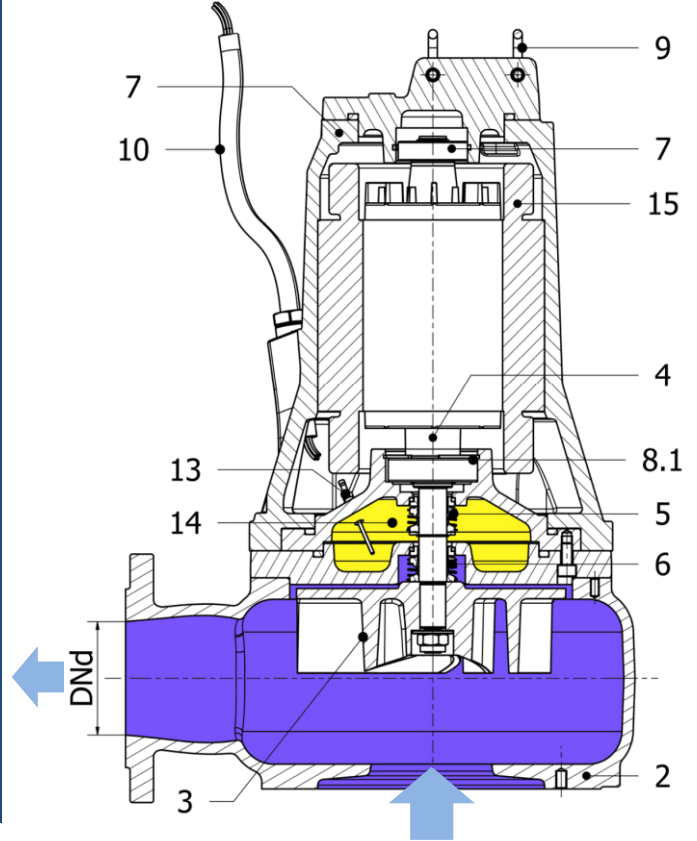

Pos.	Description	Descrizione	Material - Materiale
1	Motor body	Corpo motore	Cast Iron GG25 - Ghisa
2	Pump body	Corpo idraulico	Cast Iron GG25 - Ghisa
3	Impeller	Girante	Cast Iron GG25 - Ghisa
4	Shaft	Albero	Steel AISI 420B - Acciaio
5	Mechanical seal (motor side)	Tenuta meccanica (lato motore)	Carbon graphite / Al-Oxide - NBR
6	Mechanical seal (pump side)	Tenuta meccanica (lato pompa)	Silicon carbide / Silicon Carbide
7	Upper bearing	Cuscinetto superiore	6305-2RS1
8	Lower bearing	Cuscinetto inferiore	3207-2RS1
8.1	Lower bearing	Cuscinetto inferiore	6307-2RS1
9	Shackle to handle pump	Grillo per movimentazione	Steel AISI 304 - Acciaio
10	Supply Cable	Cavo elettrico	H07RN-F [10m]
11	Shaft protection sleeve	Bussola protezione albero	Steel AISI 304 - Acciaio
12	Radial lip seal ring	Anello tenuta radiale	NBR
13	Oil probe (optional)	Sonda olio (optional)	
14	Oil chamber - cooling and lubrication of mechanical seal	Camera olio - raffreddamento e lubrificazione tenuta meccanica	
15	Class H Stator	Statore in Classe H	
	Built in Thermal protector	Pastiglie termiche	Bimetal - Bimetallico
DNd	Delivery outlet	Bocca di mandata	Ø100 mm - PN10-PN16
	Screw quality grade	Grado di qualità delle viti	A2

OVERALL DIMENSIONS - DIMENSIONI D'INGOMBRO

VS.100_[GM.173]

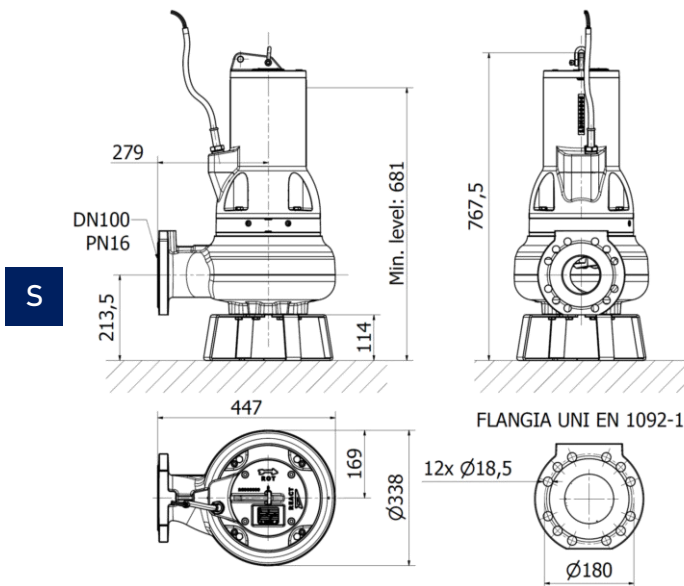

VS.100_[GM.200]

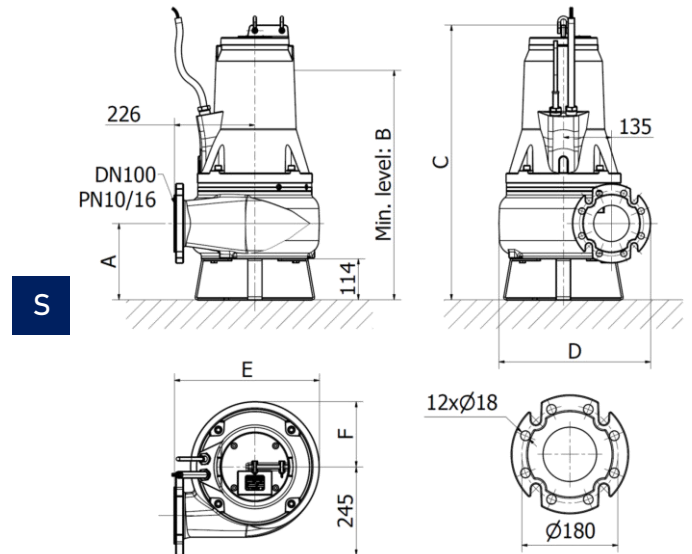

	A	B	C	D	E	F
4 poles	212	637	762	426	407	181
2 poles	194	607	697	433	414	188

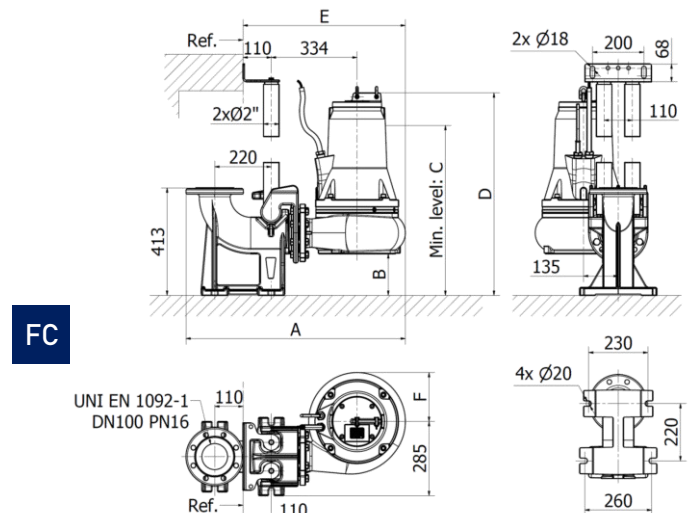
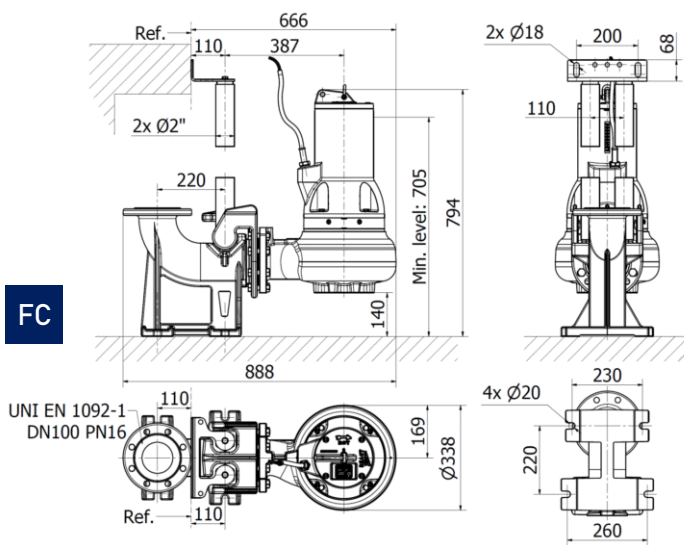

	A	B	C	D	E	F
4 poles	848	142	665	790	626	181
2 poles	853	160	653	778	632	188

INSTALLATION MODES - MODALITA' D'INSTALLAZIONE

S = Transportable underwater - Trasportabile in immersione

FC = Fixed with coupling device - Fissa con dispositivo di accoppiamento

PACKAGING DIMENSIONS - DIMENSIONI IMBALLAGGIO

	mm		
	A	B	C
Pump VS.100_[GM.173] - Pompa	550	600	400
Pump VS.100_[GM.200] - Pompa	850	450	400
Foot coupling - Piede di accoppiamento	650	800	600

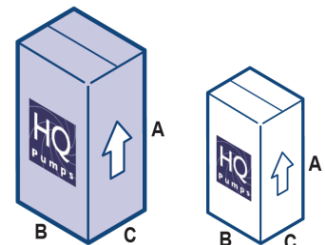

Dimensions and technical data are indicative, not binding and subjected to possible modifications without notice.
Dimensioni e dati tecnici sono indicativi, non vincolanti e soggetti a eventuali modifiche senza preavviso.

OVERALL DIMENSIONS - DIMENSIONI D'INGOMBRO

VS.100_[GM.240]

S

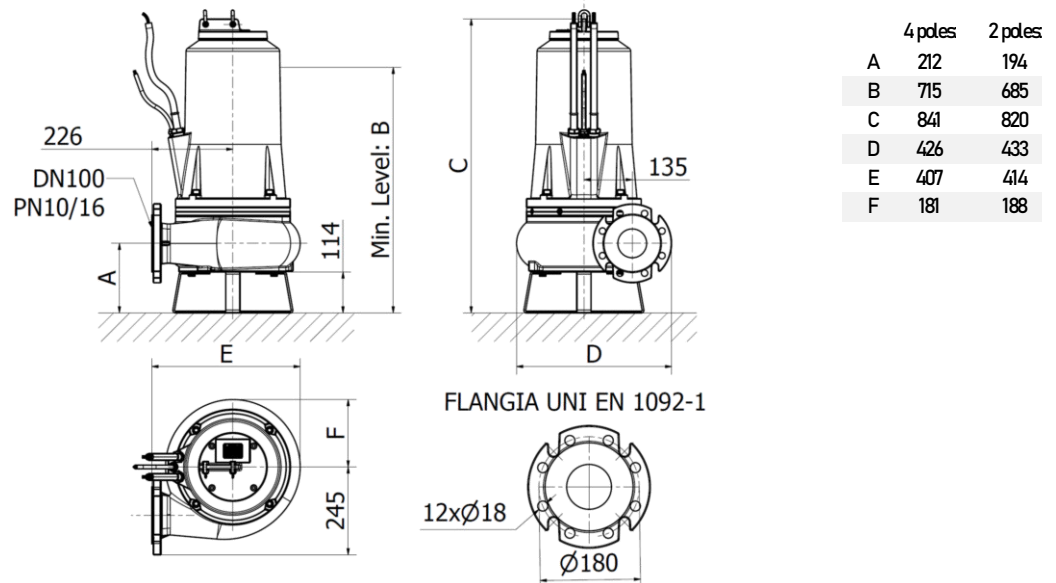

FC

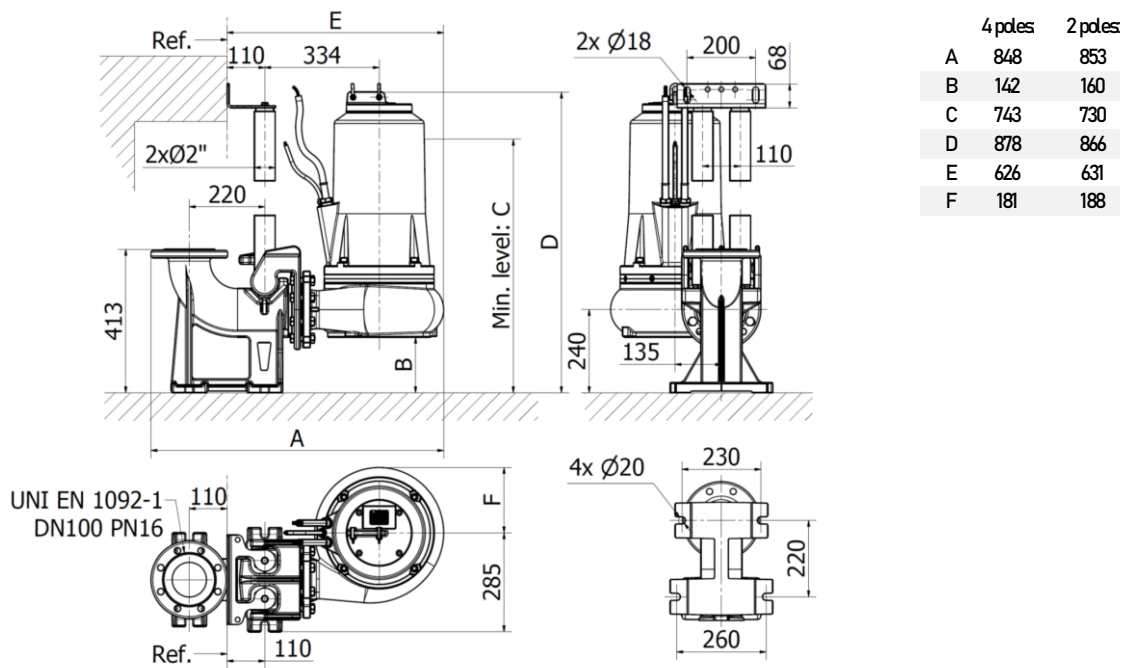

INSTALLATION MODES - MODALITA' D'INSTALLAZIONE

S

=Transportable underwater - Trasportabile in immersione

FC

=Fixed with coupling device - Fissa con dispositivo di accoppiamento

PACKAGING DIMENSIONS - DIMENSIONI IMBALLAGGIO

	mm		
	A	B	C
Pump VS.100_[GM.240] - Pompa	850	450	400
Foot coupling - Piede di accoppiamento	650	800	600

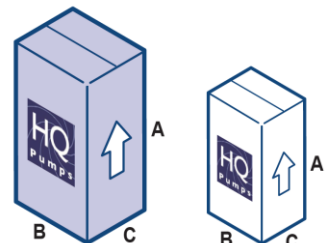

Dimensions and technical data are indicative, not binding and subjected to possible modifications without notice.
Dimensioni e dati tecnici sono indicativi, non vincolanti e soggetti a eventuali modifiche senza preavviso.

ACCESSORIES - ACCESSORI



FBV - art. 4BV00008

Flanged DN100 PN16
Flangiata DN100 PN16



SHELL - art. 3CS000021

Counterweight for level switch
Contrappeso per galleggiante



HF - art. 3CS000007

Level switch for sewage (10 m el. cable)
Regolatore di livello per acque reflue (cavo el. 10 m)



INT 69F - art. 2EC000040

Protection Relay for temperature and leakage monitoring

Relè di protezione per il monitoraggio della temperatura e delle perdite

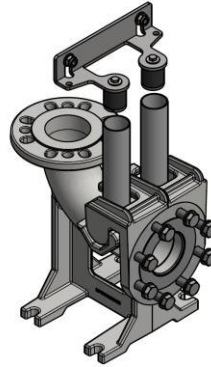

FC - art. 8FC000006

DN100 PN16 Coupling device with:
- Sliding Bracket + screws + gaskets
- Upper rail guide support

Dispositivo di accoppiamento DN100 PN16 compreso di:
- Slitta + viti + guarnizioni
- Supporto superiore per tubi guida

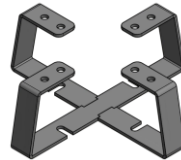

FC - art. 8FC000005

Stainless steel support stand
Cavalletto di sostegno in acciaio inox



AT 100 - art. 2SB000007

Adapter for competitors foot coupling device
Adattatore per dispositivo di accoppiamento di terze parti



ECH



ECL

ECH - ELECTROMECHANICAL ELETTROMECCANICO

1 Pump

2 Pumps

VS.100_[GM.173]	P ₂ [kW]	I _n [A]	Avv. Start.	
VS.100_30.4T	- 4 poles	3,0	7	DOL
VS.100_40.4T	- 4 poles	4,0	8,5	DOL
VS.100_37.2T	- 2 poles	3,7	8,5	DOL
VS.100_44.2T	- 2 poles	4,4	10	DOL
VS.100_55.2T	- 2 poles	5,5	13	S/D
VS.100_75.2T	- 2 poles	7,5	16	S/D
VS.100_[GM.200]				
VS.100_55.4T	- 4 poles	5,5	13	S/D
VS.100_75.4T	- 4 poles	7,5	15	S/D
VS.100_90.2T	- 2 poles	9,0	19	S/D
VS.100_[GM.240]				
VS.100_90.4T	- 4 poles	9,0	18,5	S/D
VS.100_110.2T	- 2 poles	11,0	23	S/D
VS.100_130.2T	- 2 poles	13,0	29	S/D
VS.100_150.2T	- 2 poles	15,0	32	S/D

		1 Pump								2 Pumps															
		ECH-T-7-14	5EC000007	ECH-T-14-22	5EC000009	ECH-SD-10-14	5EC000105	ECH-SD-15-20	5EC000106	ECH-SD-22-28	5EC000013	ECH-SC-28-35	5EC000014	ECH-2T-7-14	5EC000031	ECH-2T-14-22	5EC000033	ECH-2SD-10-14	5EC000107	ECH-SD-15-20	5EC000108	ECH-SD-22-28	5EC000037	ECH-SD-28-35	5EC000038
		.												.											
		.												.											
		.												.											
		.												.											
		.												.											
		.												.											
		.												.											
		.												.											
		.												.											
		.												.											
		.												.											

ECL - ELECTRONIC ELETRONICO

1 Pump

2 Pumps

		ECL-T-15	5EC000083	ECL-T-24	5EC000086	ECH-2T-15	5EC000084	ECH-2T-24	5EC000087
		.				.			
		.				.			
		.				.			
		.				.			
		.				.			
		.				.			
		.				.			
		.				.			
		.				.			