



## SUBMERSIBLE

## PUMPS FOR DIRTY WATERS

with closed impeller [CS] suitable for sludge and waste waters with suspended solids

## POMPE

## SOMMERGIBILI PER ACQUE SPORCHE

con girante chiusa [CS] idonea per fanghi e acque di scarico con solidi sospesi

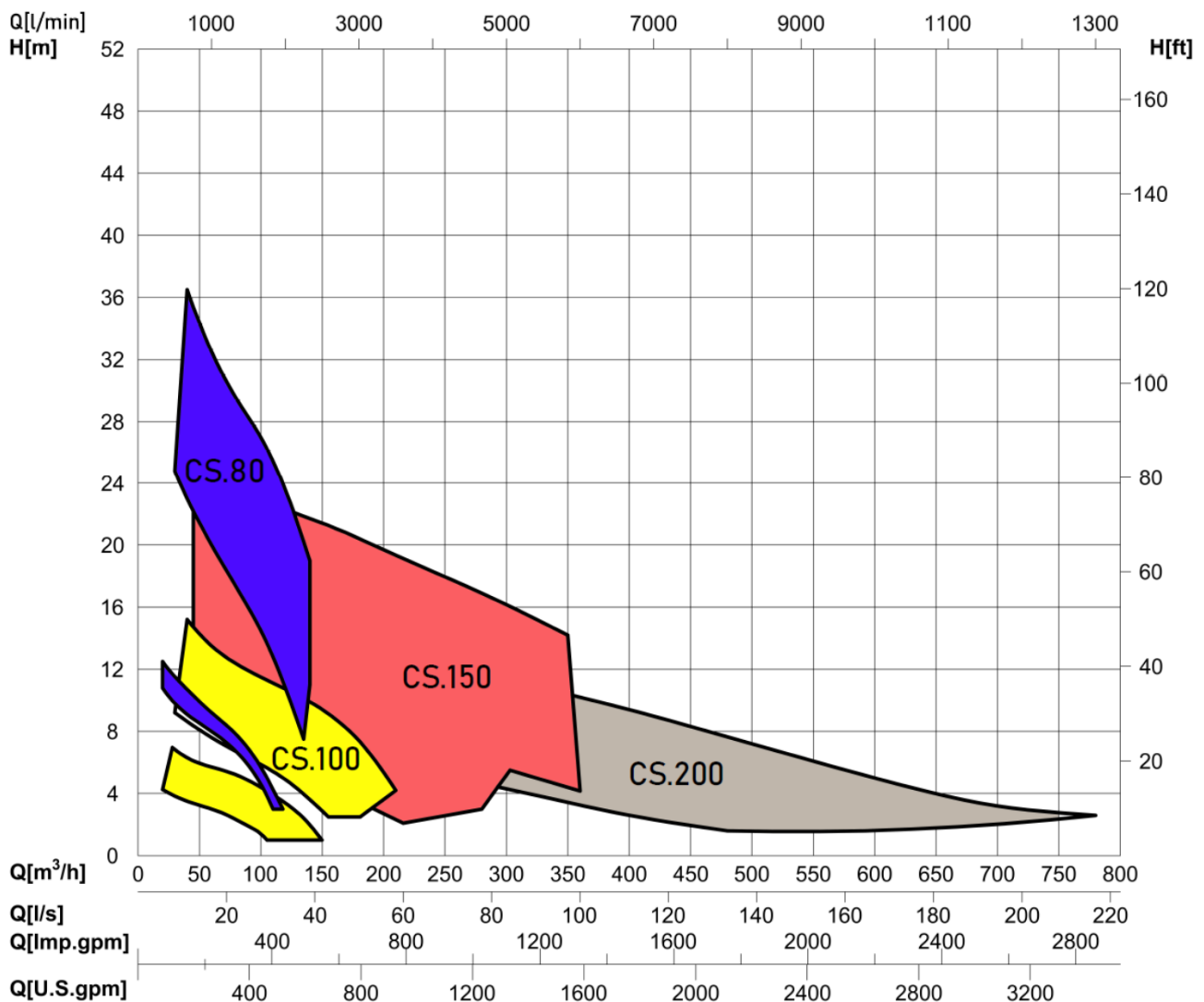

EN

Submersible pumps with closed impeller (single channel or three channels). Hydraulic solution that guarantees a good free passage of solids reducing the risk of blocking and clogging of the impeller.

Very suitable to pump sewage in the waste water treatment sites.

- 1 Cast Iron G25 Motor Body.  
Corpo motore in ghisa GG25.
- 2 Stator (3 ~ Class H).  
Statore avvolto (3 ~ in classe H).
- 3 Oil Chamber - Cooling and lubrication of the mechanical seals.  
Camera olio - raffreddamento e lubrificazione delle tenute meccaniche.
- 4 Mechanical seals.  
Tenute meccaniche.
- 5 Closed impeller.  
Girante chiusa.
- 6 GG25 Cast iron body pump.  
Corpo Pompa in ghisa GG25.

### Area of use / Settori d'impiego

- Waste water treatment - civil / industrial plants  
Trattamento delle acque di scarico - impianti civili / industriali.
- Drainage and lifting in domestic and residential systems.  
Drenaggio e sollevamento in impianti domestici e residenziali.

### Types of installation - Tipi di installazione

**S** Transportable underwater  
Trasportabile in immersione

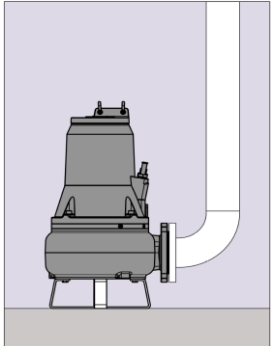

- Versatile solution suitable for various uses. A hose connection or connection flange is required for the rigid discharge line. The pump must be placed on a support stand.

- Soluzione versatile adatta a diversi impieghi. E' necessario un attacco per tubo flessibile o flangia di collegamento per la tubazione premente rigida. La pompa va posizioata su un cavalletto di sostegno.

IT

Elettropompe sommergibili con girante chiusa (monocanale o tre canali) . Soluzione idraulica che garantisce un discreto passaggio libero di corpi solidi, riducendo il pericolo di blocco della girante ed intasamento del corpo pompa.

Molto indicata per il pompaggio di reflui negli impianti di depurazione

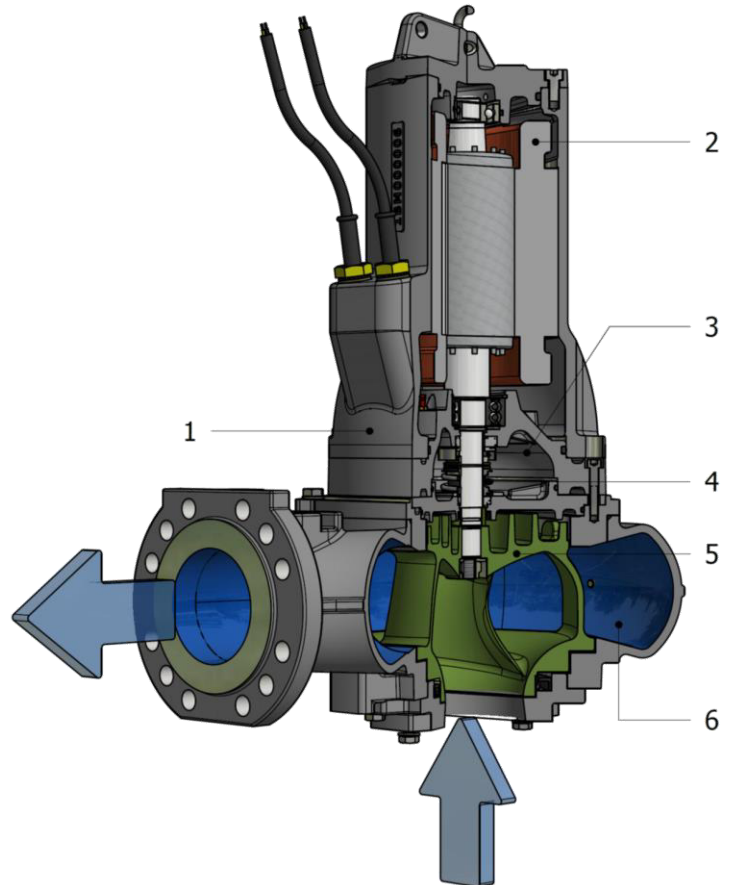

### Applications / Applicazioni

- Water and sludge from civil, industrial and domestic waste.  
Acque e fanghi provenienti da scarichi civili, industriali e domestici.
- Drainage, rainwater and process water.  
Acque di drenaggio, piovane e di processo.

**FC** Fixed submersible with coupling device  
Fissa in immersione con dispositivi di accoppiamento

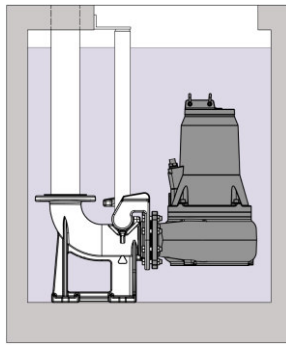

- Automatic positioning system of the pump inside the tank connected to the discharge pipe. The pump is lowered or extracted with a lifting chain; the pump slides along two guide rails until it engages with the foot coupling.

- Sistema di posizionamento automatico della pompa all'interno della vasca collegato alla tubazione premente. La pompa viene calata o estratta con catena di sollevamento; scorre lungo due tubi guida fino ad agganciarsi al piede di accoppiamento.

### CS.200\_[GM.270] series

THREE-PHASE MOTORS 3~

CS.200_110.6T_[GM.270]	- 6 poles	- 11 kW
CS.200_150.6T_[GM.270]	- 6 poles	- 15 kW
CS.200_185.6T_[GM.270]	- 6 poles	- 18,5 kW
CS.200_220.6T_[GM.270]	- 6 poles	- 22 kW



CS.200\_[GM.270]

- Submersible pumps with three channel closed impeller, compact and robust construction.
- Cast iron construction; base treatment with water-based acrylic primer and final finishing with water-based paint (30µm). Special coating with two-component epoxy resistant to abrasion on request (80µm).
- Pompe sommergibili con girante chiusa a tre canali, compatte e di robusta costruzione.
- Costruzione in ghisa; trattamento di fondo con primer acrilico a base d'acqua e rifinitura finale con vernice a base d'acqua (30µm). Rivestimento speciale con bicomponente epossidico resistente all'abrasione (80µm) su richiesta.
- Pompes submersibles avec roue à trois canal, construction compacte et robuste.
- Construction en fonte ; traitement de base avec apprêt acrylique à base d'eau et finition finale avec peinture à base d'eau (30µm). Revêtement spécial avec époxy bi-composant résistant à l'abrasion (80µm) sur demande.
- Bombas sumergibles con impulsor a tres canales, construcción compacta y robusta.
- Construcción de hierro fundido; tratamiento base con imprimación acrílica al agua y acabado final con barniz al agua (30µm). Revestimiento especial con epoxy bicomponente (80µm) resistente a la abrasión, bajo pedido.

### OPERATING LIMITS - LIMITI DI UTILIZZO

- Tmax = 40 °C standard product  
Tmax = 70 °C special version  
6 ≤ PH ≤ 12  
Chloride content < 200 mg/l  
Abrasive solid content < 1mg/l  
Density ~ 1 kg/dm<sup>3</sup>  
Viscosity ~ 1 mm<sup>2</sup>/s;
- Tmax = 40 °C prodotto standard  
Tmax = 70 °C versioni speciali  
6 ≤ PH ≤ 12  
Contenuto cloruri < 200 mg/l  
Contenuto solidi abrasivi < 1mg/l  
Densità ~ 1kg/dm<sup>3</sup>  
Viscosità ~ 1mm<sup>2</sup>/s;
- Tmax = 40 °C produit standard  
Tmax = 70 °C versions spéciales  
6 ≤ PH ≤ 12  
Teneur en chlorure < 200 mg/l  
Teneur en solides abrasifs < 1mg/l  
Densité ~ 1kg/dm<sup>3</sup>  
Viscosité ~ 1mm<sup>2</sup>/s;
- Tmax = 40 °C producto estándar  
Tmax = 70 °C versiones especiales  
6 ≤ PH ≤ 12  
Contenido de cloruro < 200 mg/l  
Contenido sólidos abrasivos < 1mg/l  
Densidad ~ 1kg/dm<sup>3</sup>  
Viscosidad ~ 1mm<sup>2</sup>/s;

### TECHNICAL DATA - DATI TECNICI

	CS.200_[GM.270]			
MODELS - MODELLI	CS.200_110.6T_[GM.240]	CS.200_150.6T_[GM.240]	CS.200_185.6T_[GM.240]	CS.200_220.6T_[GM.240]
RPM/Poles - NGiri al min / N° poli	1000 / 6	1000 / 6	1000 / 6	1000 / 6
P2: Shaft power - Potenza all'albero [kW]	11,0	15,0	18,5	22,0
PI: Input Power - Potenza assorbita [kW]	11,2	13,4	17	22,5
Power Factor - Fattore di potenza [Cosφ]	0,73	0,72	0,70	0,72
Power supply/Freq - Alimentazione/Freq [V/Hz]	3 ~ 400 / 50	4 ~ 400 / 50	5 ~ 400 / 50	6 ~ 400 / 50
Single-phase - Monofase				
Three-phase - Triase	•	•	•	•
Starting - Avviamento	S.D.	S.D.	S.D.	S.D.
Rated current - Corrente nominale [A]	22	27	35	45
Starting current - Corrente di spunto [A] - DQL/SD	121 / 40,3	148,5 / 49,5	192,5 / 64,2	247,5 / 82,5
Free Passage - Passaggio libero Ø [mm]	75	75	75	75
Impeller diameter - Diametro girante [mm]	300,0	322,0	345,0	366,0
Float level switch - Galleggiate	-	-	-	-
Power cable type/length - Cavo alim tipo/lungh. [m]		2x H07RN-F 4G6 / 10		
Signal cable type/length - Cavo segn. tipo/lungh. [m]		1x H07RN-F 4G1,5 / 10		
N° Starts per hour - N° Avviamenti / ora	10	10	10	10
Pump weight - Peso pompa [kg]	465	475	490	505

- A** = CS.200\_110.6T\_[GM270] - 11 kW
- B** = CS.200\_150.6T\_[GM270] - 15 kW
- C** = CS.200\_185.6T\_[GM270] - 18,5 kW
- D** = CS.200\_220.6T\_[GM270] - 22 kW

50 Hz Three-phase motors - 6 poles - 1000 rpm

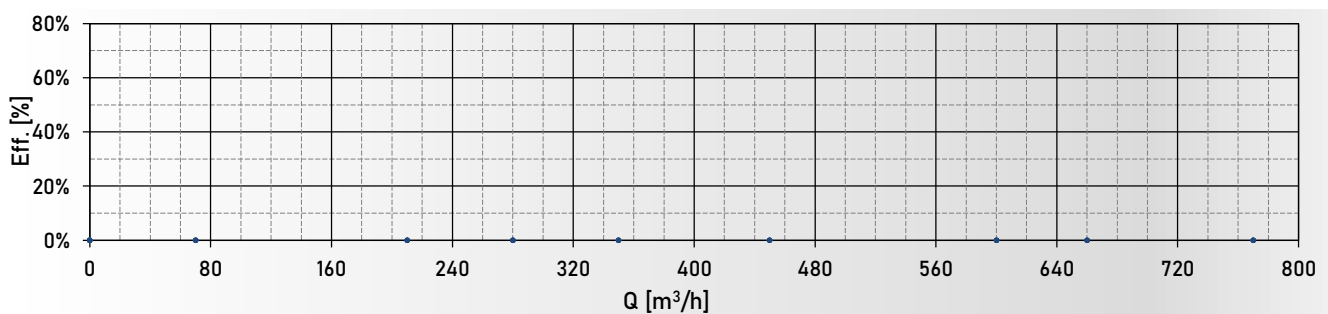
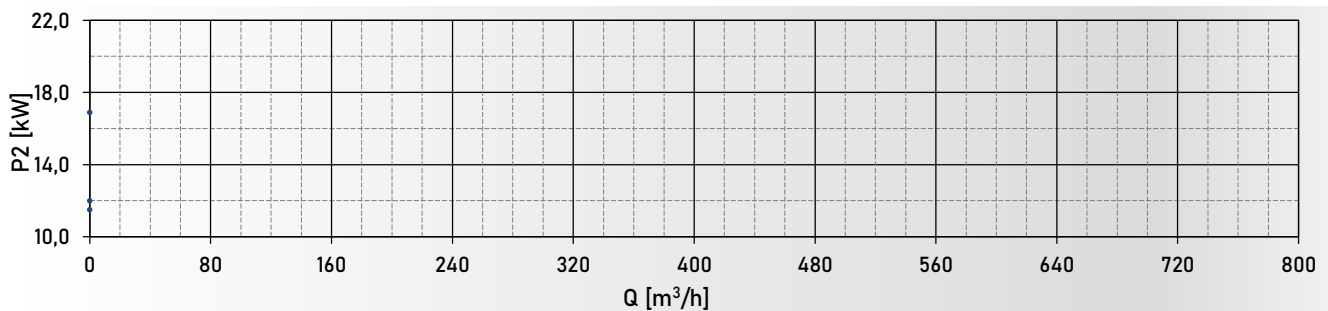
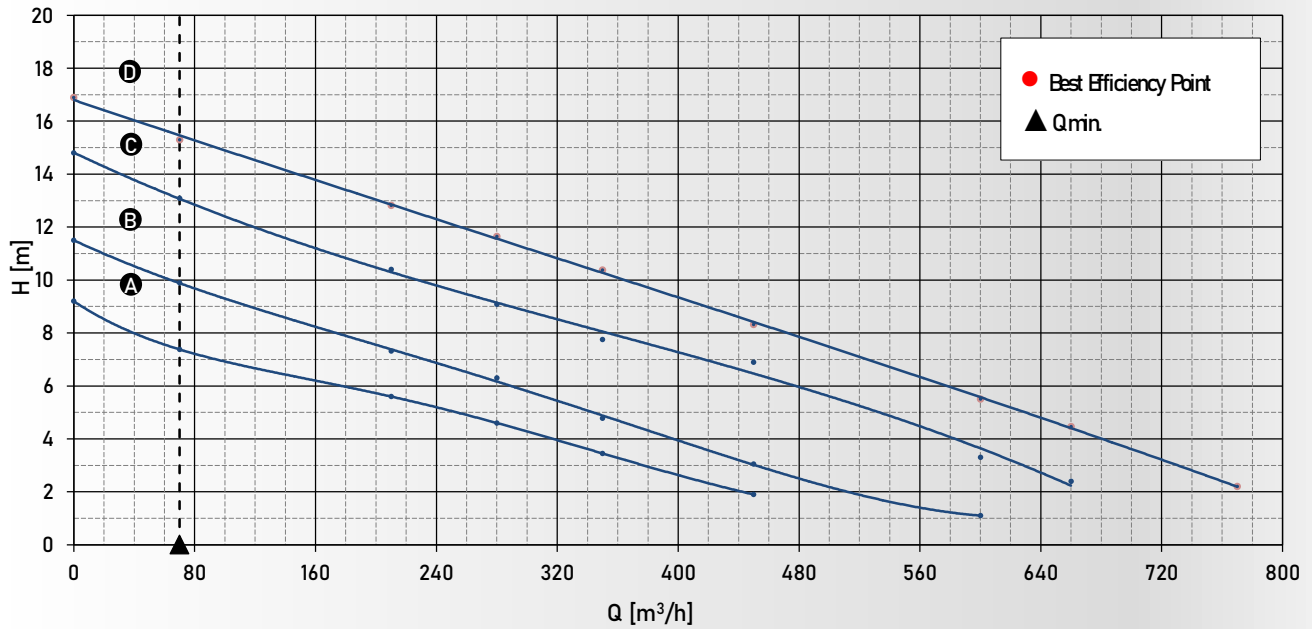

Q										
	m³/h	0	70	210	280	350	450	600	660	770
	L/min	0	1167	3500	4667	5833	7500	10000	11000	12833
L/s	0	19,4	58,3	77,8	97,2	125,0	166,7	183,3	213,9	

	0	70	210	280	350	450	600	660	770	H [m]
<b>A</b> = CS.200_110.6T_[GM270]	9,2	7,4	5,6	4,6	3,5	1,9				
<b>B</b> = CS.200_150.6T_[GM270]	11,5	9,9	7,3	6,3	4,8	3,1	1,1			
<b>C</b> = CS.200_185.6T_[GM270]	14,8	13,1	10,4	9,1	7,8	6,9	3,3	2,4		
<b>D</b> = CS.200_220.6T_[GM270]	16,9	15,3	12,8	11,7	10,4	8,3	5,5	4,5	2,2	

CS.200\_[GM.270]

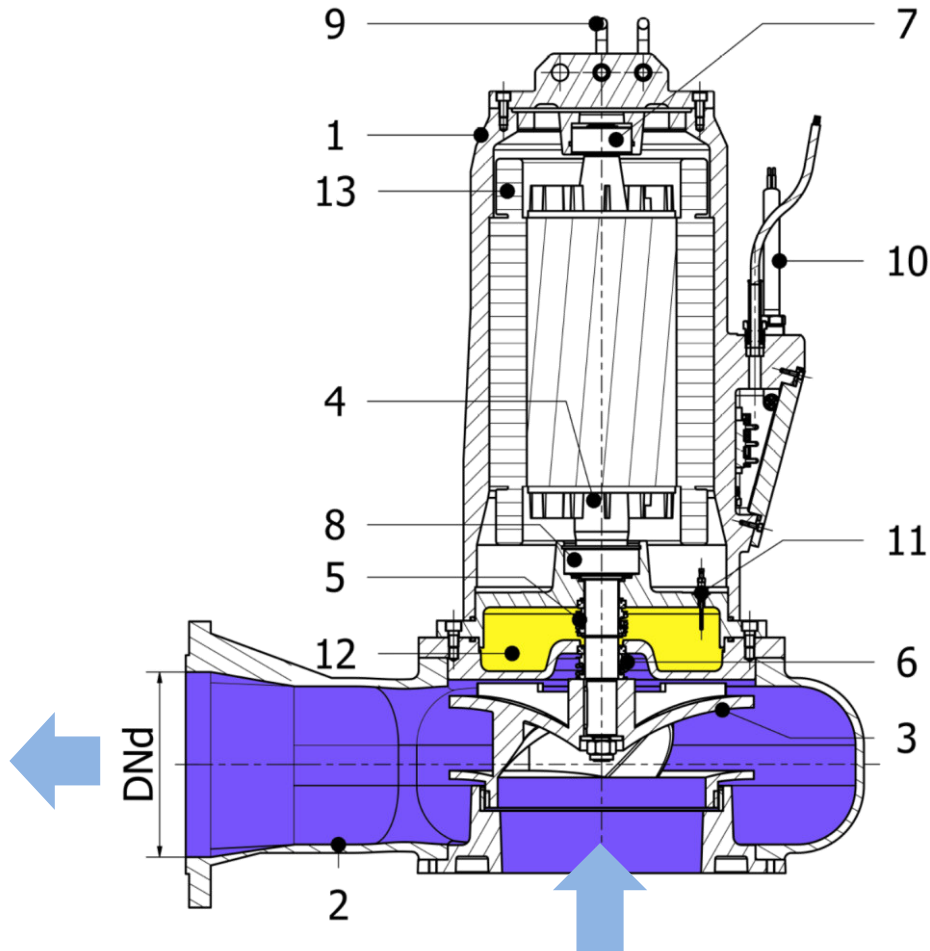

Pos.	Description	Descrizione	Material - Materiale
1	Motor body	Corpo motore	Cast Iron GG25 - Ghisa
2	Pump body	Corpo idraulico	Cast Iron GG25 - Ghisa
3	Impeller	Girante	Cast Iron GG25 - Ghisa
4	Shaft	Albero	Steel AISI 420B - Acciaio
5	Mechanical seal (motor side)	Tenuta meccanica (lato motore)	Carbon graphite / Al-Oxide - NBR
6	Mechanical seal (pump side)	Tenuta meccanica (lato pompa)	Silicon carbide / Silicon Carbide
7	Upper bearing	Cuscinetto superiore	3306 A - 2RS1
8	Lower bearing	Cuscinetto inferiore	3210 A - 2 RS1
9	Shackle	Grillo	Steel AISI 304 - Acciaio
10	Supply Cable	Cavo elettrico	H07RN-F [10m]
11	Oil probe (optional)	Sonda olio (optional)	
12	Oil chamber - cooling and lubrication of mechanical seal	Camera olio - raffreddamento e lubrificazione tenuta meccanica	
13	Class H stator Built in Thermal protector	Motore in Classe H Pastiglie termiche	Bimetal - Bimetallico
DNd	Delivery outlet Screw quality grade	Bocca di mandata Grado di qualità delle viti	Ø200 mm - PN10-PN16 A2

### OVERALL DIMENSIONS - DIMENSIONI D'INGOMBRO

CS.200\_[GM.270]

**S**

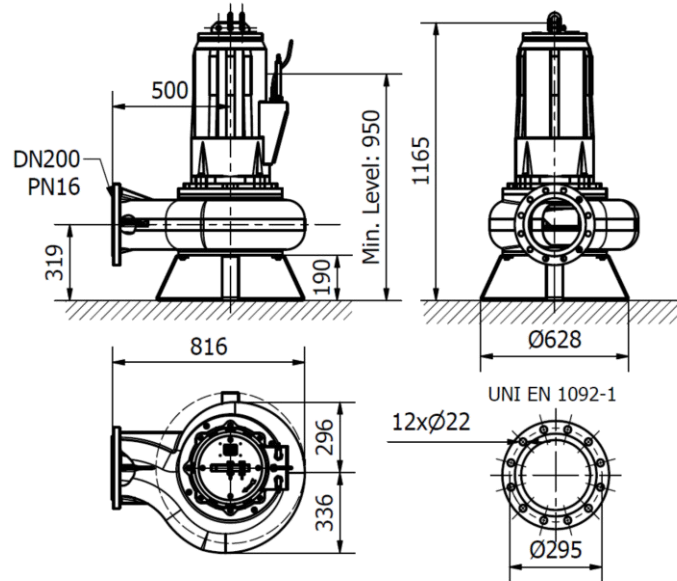

**FC**

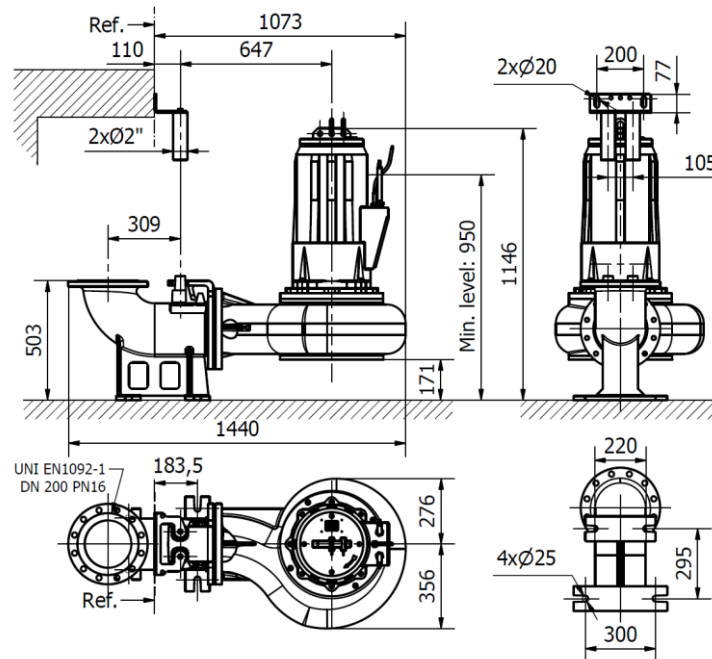

### INSTALLATION MODES - MODALITA' D'INSTALLAZIONE

**S**

=Transportable underwater - Trasportabile in immersione

**FC**

= Fixed with coupling device - Fissa con dispositivo di accoppiamento

### PACKAGING DIMENSIONS - DIMENSIONI IMBALLAGGIO

	mm		
	A	B	C
Pump CS.200_[GM.270](wood cage) - Pompa (gabbia in legno) (*)	1430	925	1050
Foot coupling - Piede di accoppiamento (*)	700	800	600

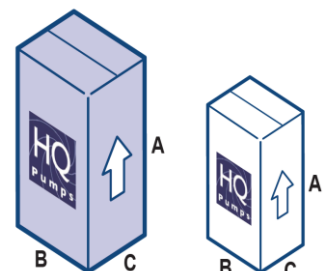

(\*) Pallet included - Incluso il pallet

Dimensions and technical data are indicative, not binding and subjected to possible modifications without notice.

Dimensioni e dati tecnici sono indicativi, non vincolanti e soggetti a eventuali modifiche senza preavviso.

### ACCESSORIES - ACCESSORI



**FBV - art. 4BV000010**

Flanged DN 200 PN 16 - Flangiata



**SHELL - art. 3CS000021**

Counterweight for level switch  
Contrappeso per galleggiante



**HF - art. 3CS000007**

Level switch for sewage (10 m el. cable)  
Regolatore di livello per acque reflue (cavo el. 10 m)



**INT 69F - art. 2EC000040**

Protection Relay for temperature and leakage monitoring

Relè di protezione per il monitoraggio della temperatura e delle perdite

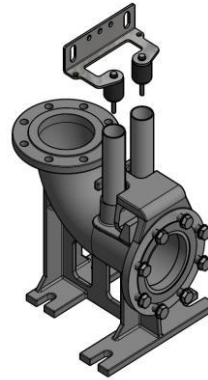

**FC - art. 8FC000016**

DN 200 PN 16 Coupling device with:  
- Sliding Bracket + screws + gaskets  
- Upper rail guide support

Dispositivo di accoppiamento DN200 PN16 compreso di:  
- Slitta + viti + guarnizioni  
- Supporto superiore per tubi guida

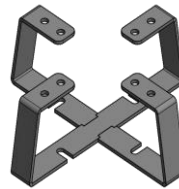

**FC - art. 8FC000018**

Galvanized steel support stand  
Cavalletto di sostegno in ferro zincato



**AT 100 - art. 2SB000012**

Adapter for competitors foot coupling device  
Adattatore per dispositivo di accoppiamento di terze parti



**ECH**

### ECH - ELECTROMECHANICAL ELETTROMECCANICO

CS.200_[GM.270]	P <sub>2</sub> [kW]	In [A]	Av. Start.
CS.200_110.6T_[GM.270] - 6 poles	11	22,0	S/D
CS.200_150.6T_[GM.270] - 6 poles	15	27,0	S/D
CS.200_185.6T_[GM.270] - 6 poles	18,5	35,0	S/D
CS.200_220.6T_[GM.27] - 6 poles	22	45,0	S/D

1 Pump		2 Pumps			
ECH1.SD 22-28 5EC000013	ECH1.SD 28-35 5EC000014	ECH1.SD 43-50 5EC000016	ECH2.SD 22-28 5EC000037	ECH2.SD 28-35 5EC000038	ECH2.SD 43-50 5EC000040
.	.	.	.	.	.
.	.	.	.	.	.
.	.	.	.	.	.