



SUBMERSIBLE

PUMPS FOR DIRTY WATERS

with closed impeller [CS] suitable for sludge and waste waters with suspended solids

POMPE

SOMMERGIBILI PER ACQUE SPORCHE

con girante chiusa [CS] idonea per fanghi e acque di scarico con solidi sospesi

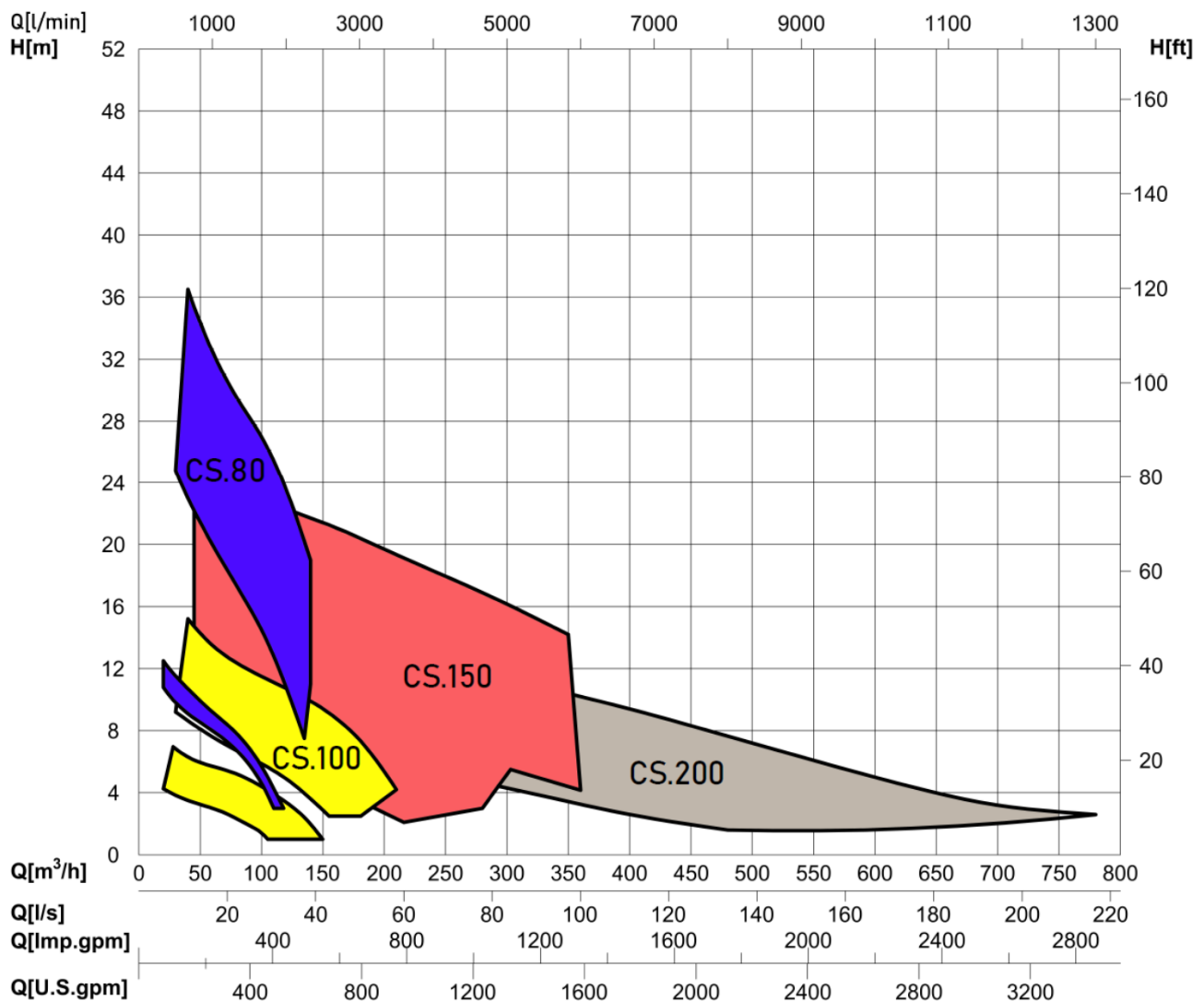

EN

Submersible pumps with closed impeller (single channel or three channels). Hydraulic solution that guarantees a good free passage of solids reducing the risk of blocking and clogging of the impeller.

Very suitable to pump sewage in the waste water treatment sites.

- 1 Cast Iron G25 Motor Body.
Corpo motore in ghisa GG25.
- 2 Stator (3 ~ Class H).
Statore avvolto (3 ~ in classe H).
- 3 Oil Chamber - Cooling and lubrication of the mechanical seals.
Camera olio - raffreddamento e lubrificazione delle tenute meccaniche.
- 4 Mechanical seals.
Tenute meccaniche.
- 5 Closed impeller.
Girante chiusa.
- 6 GG25 Cast iron body pump.
Corpo Pompa in ghisa GG25.

Area of use / Settori d'impiego

- Waste water treatment - civil / industrial plants
Trattamento delle acque di scarico - impianti civili / industriali.
- Drainage and lifting in domestic and residential systems.
Drenaggio e sollevamento in impianti domestici e residenziali.

Types of installation - Tipi di installazione

S Transportable underwater
Trasportabile in immersione

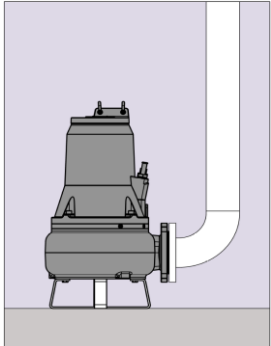

- Versatile solution suitable for various uses. A hose connection or connection flange is required for the rigid discharge line. The pump must be placed on a support stand.

- Soluzione versatile adatta a diversi impieghi. E' necessario un attacco per tubo flessibile o flangia di collegamento per la tubazione premente rigida. La pompa va posizioata su un cavalletto di sostegno.

IT

Elettropompe sommergibili con girante chiusa (monocanale o tre canali) . Soluzione idraulica che garantisce un discreto passaggio libero di corpi solidi, riducendo il pericolo di blocco della girante ed intasamento del corpo pompa.

Molto indicata per il pompaggio di reflui negli impianti di depurazione

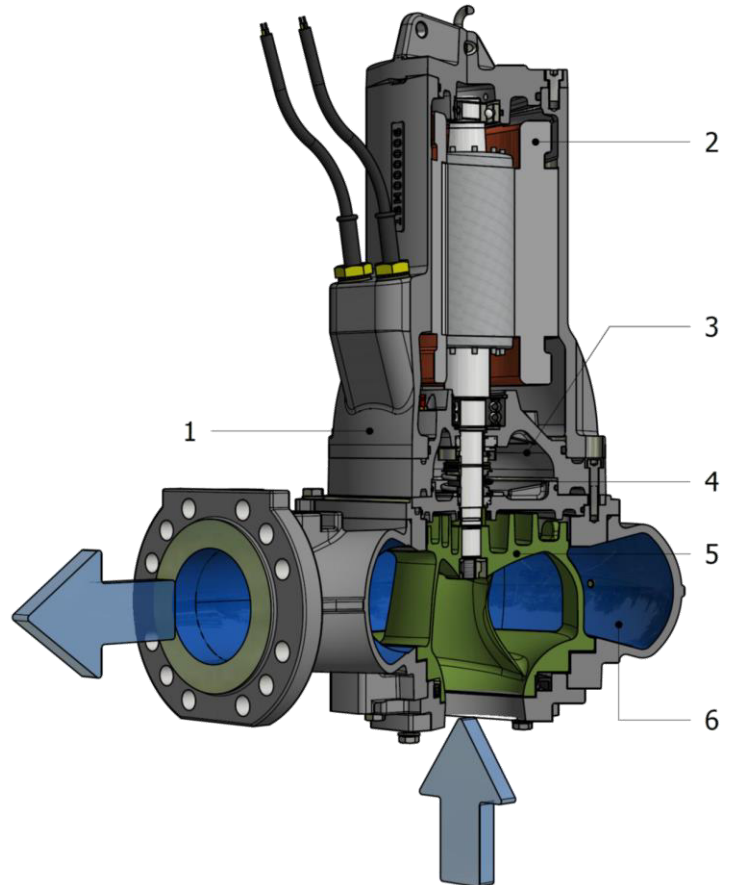

Applications / Applicazioni

- Water and sludge from civil, industrial and domestic waste.
Acque e fanghi provenienti da scarichi civili, industriali e domestici.
- Drainage, rainwater and process water.
Acque di drenaggio, piovane e di processo.

FC Fixed submersible with coupling device
Fissa in immersione con dispositivi di accoppiamento

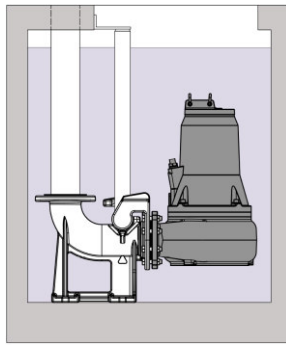

- Automatic positioning system of the pump inside the tank connected to the discharge pipe. The pump is lowered or extracted with a lifting chain; the pump slides along two guide rails until it engages with the foot coupling.

- Sistema di posizionamento automatico della pompa all'interno della vasca collegato alla tubazione premente. La pompa viene calata o estratta con catena di sollevamento; scorre lungo due tubi guida fino ad agganciarsi al piede di accoppiamento.

CS.150_[GM.240] series

THREE-PHASE MOTORS 3~

CS.150_55.6T_[GM.240] - 6 poles - 5,5 kW

CS.150_90.4T_[GM.240] - 4 poles - 9,0 kW

CS.150_110.4T_[GM.240] - 4 poles - 11,0 kW

CS.150_150.4T_[GM.240] - 4 poles - 15,0 kW

CS.150_[GM.270] series

THREE-PHASE MOTORS 3~

CS.150_75.6T_[GM.270] - 6 poles - 7,5 kW

CS.150_185.4T_[GM.270] - 4 poles - 18,5 kW



CS.150_[GM.240]



CS.150_[GM.270]

- Submersible pumps with single channel closed impeller, compact and robust construction.
- Pompe sommergibili con girante chiusa monocanale, compatte e di robusta costruzione.
- Pompes submersibles avec roue monocanal, construction compacte et robuste.
- Bombas sumergibles con impulsor monocanal, construcción compacta y robusta.
- Cast iron construction; base treatment with water-based acrylic primer and final finishing with water-based paint (30µm). Special coating with two-component epoxy resistant to abrasion on request (80µm).
- Costruzione in ghisa; trattamento di fondo con primer acrilico a base d'acqua e rifinitura finale con vernice a base d'acqua (30µm). Rivestimento speciale con bicomponente epossidico resistente all'abrasione (80µm) su richiesta.
- Construction en fonte ; traitement de base avec apprêt acrylique à base d'eau et finition finale avec peinture à base d'eau (30µm). Revêtement spécial avec époxy bicomposant résistant à l'abrasion (80µm) sur demande.
- Construcción de hierro fundido; tratamiento base con imprimación acrílica al agua y acabado final con barniz al agua (30µm). Revestimiento especial con epoxi bicomponente (80µm) resistente a la abrasión, bajo pedido.

OPERATING LIMITS - LIMITI DI UTILIZZO

- Tmax = 40 °C standard product
Tmax = 70 °C special version
6 ≤ PH ≤ 12
Chloride content < 200 mg/l
Abrasive solid content < 1mg/l
Density ~ 1 kg/dm³
Viscosity ~ 1 mm²/s;
- Tmax = 40 °C prodotto standard
Tmax = 70 °C versioni speciali
6 ≤ PH ≤ 12
Contenuto cloruri < 200 mg/l
Contenuto solidi abrasivi < 1mg/l
Densità ~ 1kg/dm³
Viscosità ~ 1mm²/s;
- Tmax = 40 °C produit standard
Tmax = 70 °C versions spéciales
6 ≤ PH ≤ 12
Teneur en chlorure < 200 mg/l
Teneur en solides abrasifs < 1mg/l
Densité ~ 1kg/dm³
Viscosité ~ 1mm²/s;
- Tmax = 40 °C producto estándar
Tmax = 70 °C versiones especiales
6 ≤ PH ≤ 12
Contenido de cloruro < 200 mg/l
Contenido sólidos abrasivos < 1mg/l
Densidad ~ 1kg/dm³
Viscosidad ~ 1mm²/s;

TECHNICAL DATA - DATI TECNICI

	CS.150_[GM.240]				CS.150_[GM.270]	
MODELS - MODELLI	CS.150_55.6T_[GM.240]	CS.150_90.4T_[GM.240]	CS.150_110.4T_[GM.240]	CS.150_150.4T_[GM.240]	CS.150_75.6T_[GM.270]	CS.150_185.4T_[GM.270]
RPM/Poles - NGiri al min / N° poli	1000 / 6	1500 / 4	1500 / 4	1500 / 4	1000 / 6	1500 / 4
P2: Shaft power - Potenza all'albero [kW]	5,5	9,0	11,0	15,0	7,5	18,5
PI: Input Power - Potenza assorbita [kW]	6,3	12,7	14	16	7,0	22
Power Factor - Fattore di potenza [Cosφ]	0,7	0,80	0,78	0,74	0,7	0,74
Power supply/Freq - Alimentazione/Freq [V/Hz]	3 ~ 400 / 50	3 ~ 400 / 50	3 ~ 400 / 50	3 ~ 400 / 50	3 ~ 400 / 50	3 ~ 400 / 50
Single-phase - Monofase						
Three-phase - Triase	•	•	•	•	•	•
Starting - Avviamento	D.O.L. / S.D	S.D	S.D	S.D.	D.O.L. / S.D.	S.D.
Rated current - Corrente nominale [A]	13	23	26	31	19	43
Starting current - Corrente di spunto [A]	71,5 / 23,8	42,0	47,7	57,0	35,0	79,0
Free Passage - Passaggio libero Ø [mm]	95	95	95	95	108	108
Impeller diameter - Diametro girante [mm]						
Float level switch - Galleggiate	-	-	-	-	-	-
Power cable type/length - Cavo alim tipo/lunghezza [m]		2x H07RN-F 4G4 / 10			2x H07RN-F 4G6 / 10	
Signal cable type/length - Cavo segn. tipo/lunghezza [m]		1x H07RN-F 4G1,5 / 10			1x H07RN-F 4G1,5 / 10	
N° Starts per hour - N° Avviamenti / ora	20	15	15	10	15	10
Pump weight - Peso pompa [kg]	200	200	212	226	300	340

- Ⓐ = CS150_55.6T_[GM240] - 5,5 kW
- Ⓑ = CS150_75.6T_[GM270] - 7,5 kW

50 Hz Three-phase motors - 6 poles - 1000 rpm

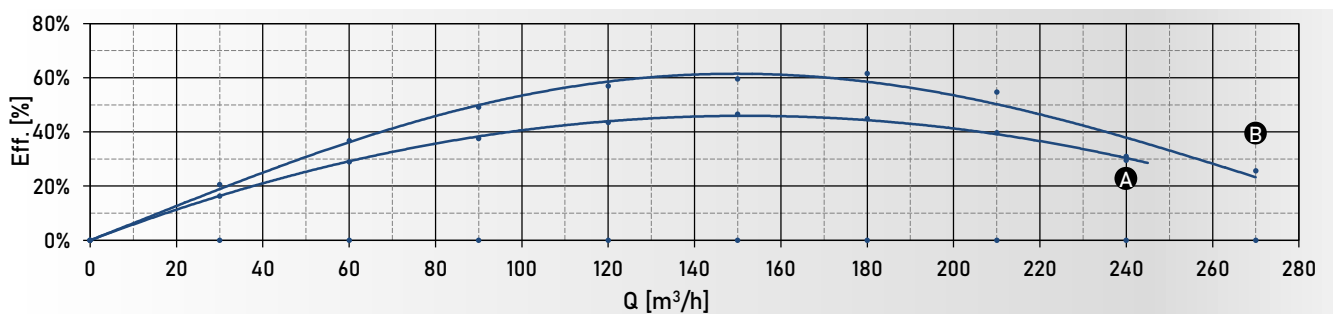
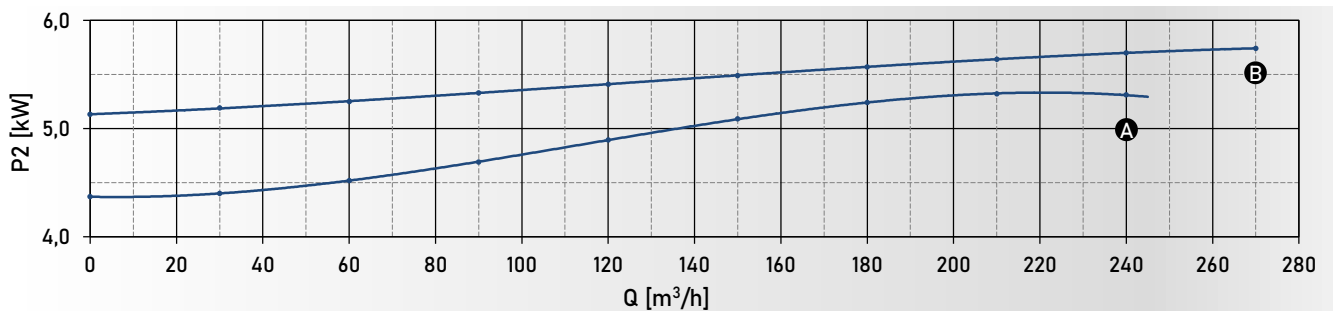
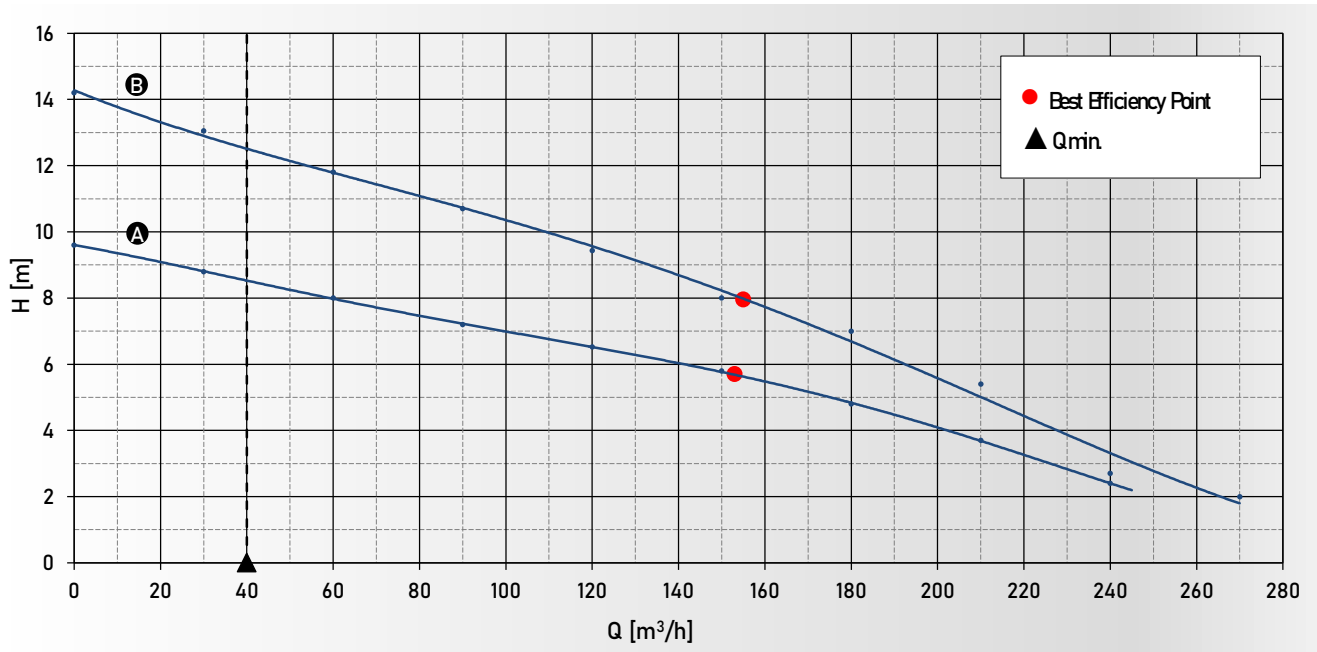

Q	m³/h	0	30	60	90	120	150	180	210	240	270
	L/min	0	500	1000	1500	2000	2500	3000	3500	4000	4500
	L/s	0	8,3	16,7	25,0	33,3	41,7	50,0	58,3	66,7	75,0

Ⓐ = CS150_55.6T_[GM240]	9,6	8,8	8,0	7,2	6,5	5,8	4,8	3,7	2,4	
Ⓑ = CS150_75.6T_[GM270]	14,2	13,1	11,8	10,7	9,4	8,0	7,0	5,4	2,7	2,0

H [m]

- A** = CS.150_90.4T_[GM240] - 9,0 kW
- B** = CS.150_110.4T_[GM240] - 11,0 kW
- C** = CS.150_150.4T_[GM240] - 15,0 kW
- D** = CS.150_185.4T_[GM270] - 18,5 kW

50 Hz Three-phase motors - 4 poles - 1500 rpm

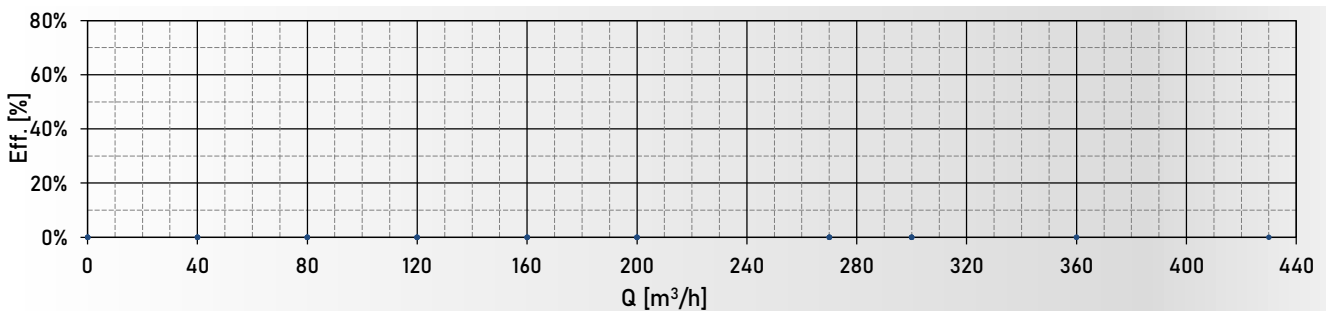
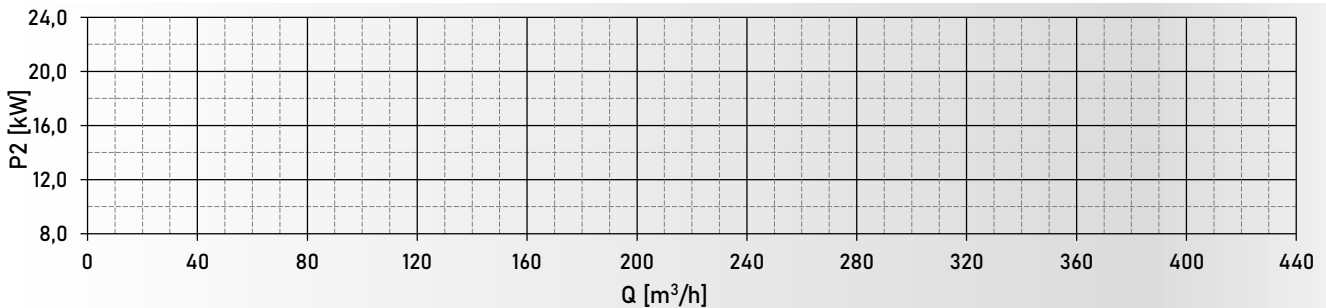
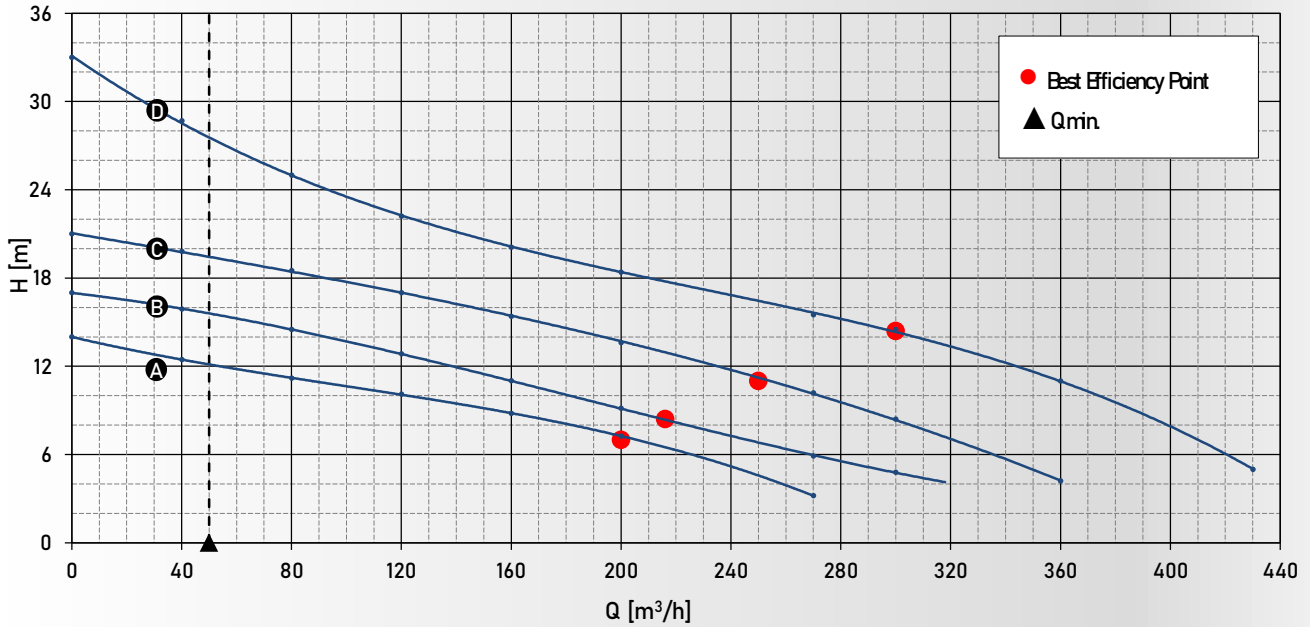

Q	m³/h	0	40	80	120	160	200	270	300	360	430
	L/min	0	667	1333	2000	2667	3333	4500	5000	6000	7167
	L/s	0	11,1	22,2	33,3	44,4	55,6	75,0	83,3	100,0	119,4

A = CS.150_90.4T_[GM240]	14,0	12,5	11,2	10,1	8,8	7,3	3,2				
B = CS.150_110.4T_[GM240]	17,0	15,9	14,5	12,8	11,0	9,2	5,9	4,8			
C = CS.150_150.4T_[GM240]	21,0	19,8	18,5	17,0	15,4	13,6	10,2	8,4	4,2		
D = CS.150_185.4T_[GM270]	33,0	28,7	25,0	22,2	20,1	18,4	15,5	14,5	11,0	5,0	

H [m]

SECTIONAL VIEWS - VISTE IN SEZIONE

CS.150_[GM.240]

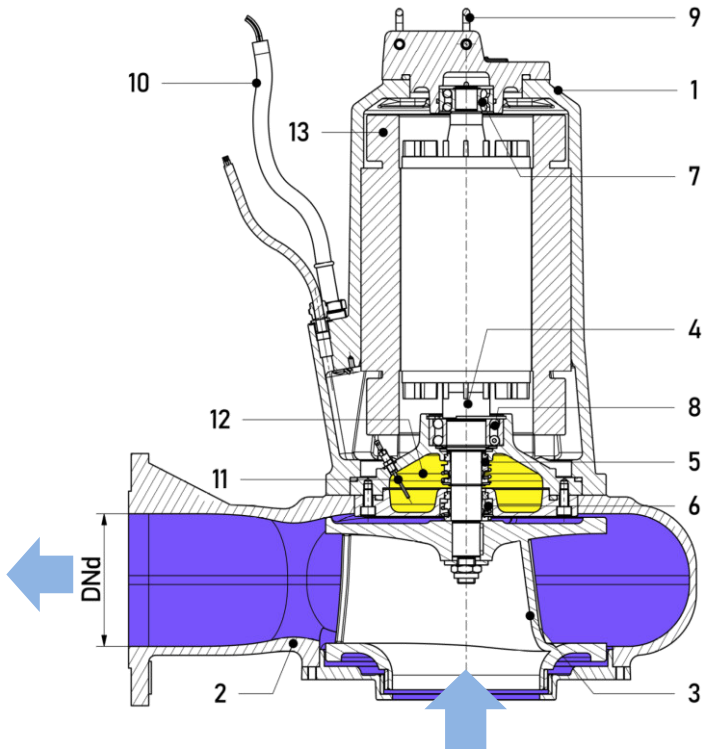

CS.150_[GM.270]

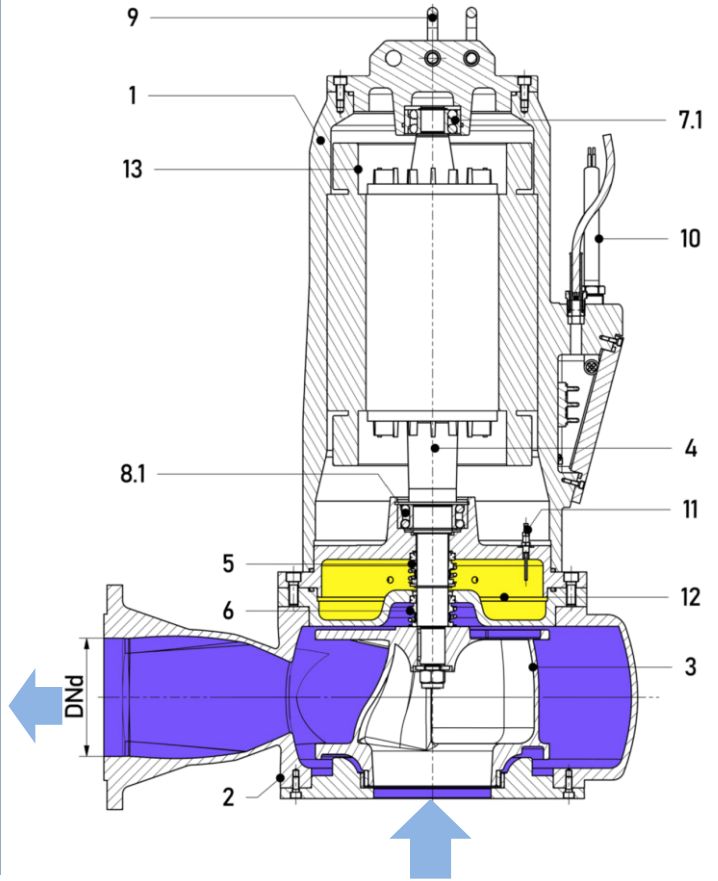

Pos.	Description	Descrizione	Material - Materiale
1	Motor body	Corpo motore	Cast Iron GG25 - Ghisa
2	Pump body	Corpo idraulico	Cast Iron GG25 - Ghisa
3	Impeller	Girante	Cast Iron GG25 - Ghisa
4	Shaft	Albero	Steel AISI 420B - Acciaio
5	Mechanical seal (motor side)	Tenuta meccanica (lato motore)	Carbon graphite / Al-Oxide - NBR
6	Mechanical seal (pump side)	Tenuta meccanica (lato pompa)	Silicon carbide / Silicon Carbide
7	Upper bearing	Cuscinetto superiore	3305 - 2RS1
7.1	Upper bearing	Cuscinetto superiore	3306 - 2RS1
8	Lower bearing	Cuscinetto inferiore	3209 - 2 RS1
8.1	Lower bearing	Cuscinetto inferiore	3210 - 2 RS1
9	Shackle	Grillo	Steel AISI 304 - Acciaio
10	Supply Cable	Cavo elettrico	H07RN-F [10m]
11	Oil probe (optional)	Sonda olio (optional)	
12	Oil chamber - cooling and lubrication of mechanical seal	Camera olio - raffreddamento e lubrificazione tenuta meccanica	
13	Class H stator Built in Thermal protector	Motore in Classe H Pastiglie termiche	Bimetal - Bimetallico
DNd	Delivery outlet Screw quality grade	Bocca di mandata Grado di qualità delle viti	Ø150 mm - PN10-PN16 A2

OVERALL DIMENSIONS - DIMENSIONI D'INGOMBRO

CS.150_[GM.240]

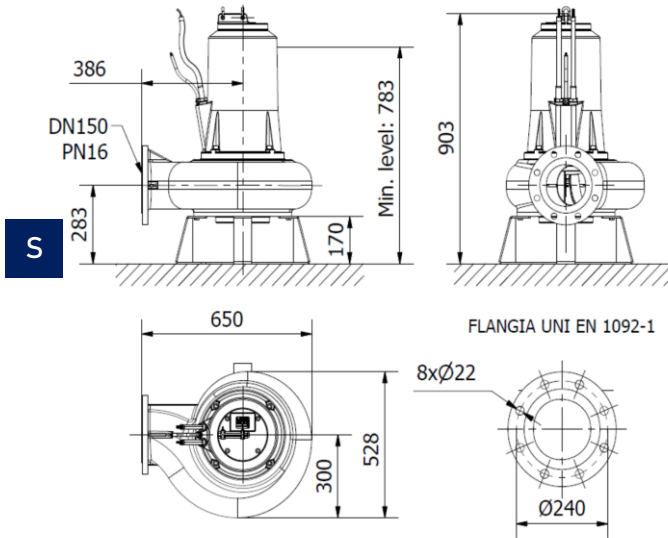

CS.150_[GM.270]

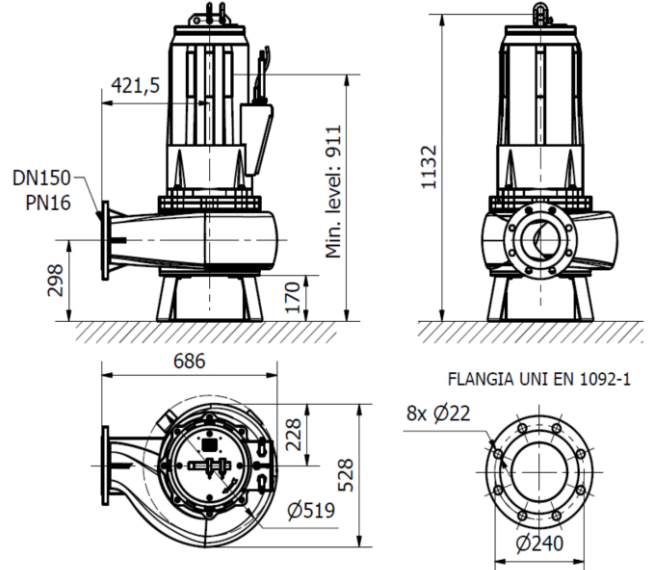

FC

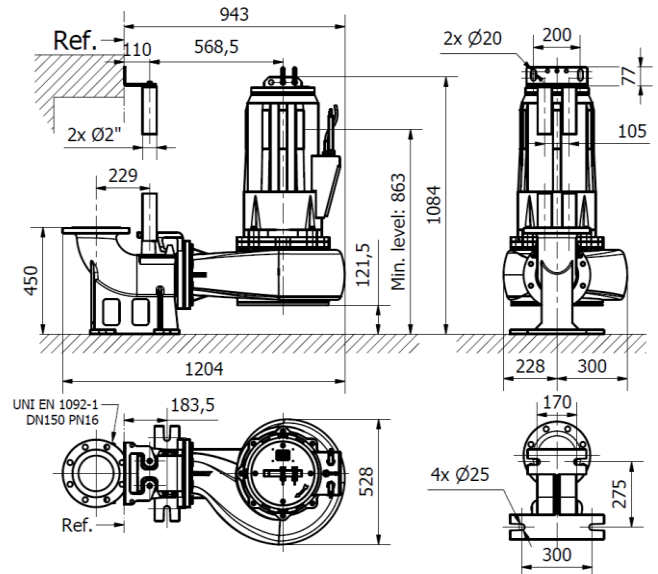
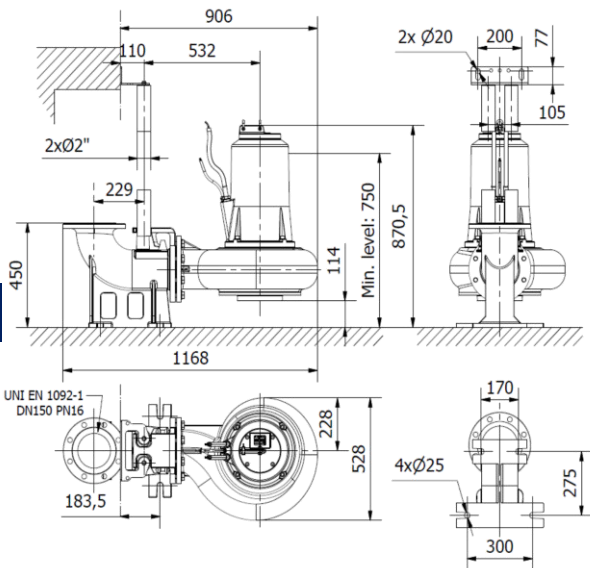

INSTALLATION MODES - MODALITA' D'INSTALLAZIONE

S = Transportable underwater - Trasportabile in immersione

FC = Fixed with coupling device - Fissa con dispositivo di accoppiamento

PACKAGING DIMENSIONS - DIMENSIONI IMBALLAGGIO

	mm		
	A	B	C
Pump CS.150_[GM.240](wood cage) - Pompa (gabbia in legno) (*)	1430	925	1050
Pump CS.150_[GM.270](wood cage) - Pompa (gabbia in legno) (*)	1430	925	1050
Foot coupling - Piede di accoppiamento (*)	700	800	600

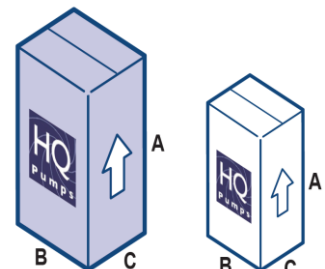

(*) Pallet included - Incluso il pallet

Dimensions and technical data are indicative, not binding and subjected to possible modifications without notice.

Dimensioni e dati tecnici sono indicativi, non vincolanti e soggetti a eventuali modifiche senza preavviso.

ACCESSORIES - ACCESSORI



FBV - art. 4BV000009

Flanged DN 150 PN 16 - Flangiata



SHELL - art. 3CS000021

Counterweight for level switch
Contrappeso per galleggiante



HF - art. 3CS000007

Level switch for sewage (10 m el. cable)
Regolatore di livello per acque reflue (cavo el. 10 m)



INT 69F - art. 2EC000040

Protection Relay for temperature and leakage monitoring

Relè di protezione per il monitoraggio della temperatura e delle perdite

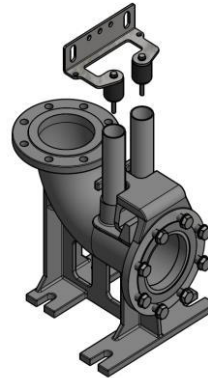

FC - art. 8FC000008

DN 150 PN 16 Coupling device with:
- Sliding Bracket + screws + gaskets
- Upper rail guide support

Dispositivo di accoppiamento DN150 PN16 compreso di:
- Slitta + viti + guarnizioni
- Supporto superiore per tubi guida

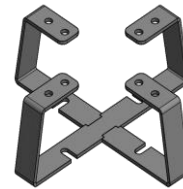

FC - art. 8FC000011

Galvanized steel support stand
Cavalletto di sostegno in ferro zincato



AT 100 - art. 2SB000009

Adapter for competitors foot coupling device
Adattatore per dispositivo di accoppiamento di terze parti



ECH



ECL

ECH - ELECTROMECHANICAL ELETTROMECCANICO

		P ₂ [kW]	I _n [A]	Av. Start.
CS.150_[GM.240]				
CS.150_55.6T_[GM.240]	- 6 poles	5,5	13,0	DDL
CS.150_90.4T_[GM.240]	- 4 poles	9	23,0	S/D
CS.150_110.4T_[GM.240]	- 4 poles	11	26,0	S/D
CS.150_150.4T_[GM.240]	- 4 poles	15	31,0	S/D
CS.150_[GM.270]				
CS.150_75.6T_[GM.270]	- 6 poles	7,5	19,0	S/D
CS.150_185.4T_[GM.270]	- 4 poles	18,5	43,0	S/D

1 Pump						2 Pumps					
ECH1.T 7-14 5EC000007	ECH1.SD 15-20 5EC000106	ECH1.SD 22-28 5EC000013	ECH1.SD 28-35 5EC000014	ECH1.SD 43-50 5EC000016	ECH2.T 7-14 5EC000031	ECH2.SD 15-20 5EC000108	ECH2.SD 22-28 5EC000037	ECH2.SD 28-35 5EC000038	ECH2.SD 43-50 5EC000040		
.		.			.		.				
			.					.			
				.					.		
	.					.					
				.					.		

ECL - ELECTRONIC ELETRONICO

1 Pump		2 Pumps	
ECL1.T-15 5EC000083		ECH2.T-15 5EC000084	
.		.	