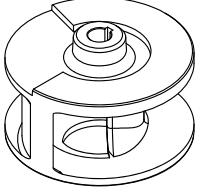

HYDROPOMPE	SINGLE CHANNEL IMPELLER 	DN 150
F SERIES		50 Hz
704/433-1154/453-1504/463		4 POLE

USE

Submersible electric pumps particularly suitable for pumping industrial sewage, screened waste water and mud in the pumping stations. They can be used also to lift clear and dirty water and rain water.

MATERIALS

Motor housing

Cast iron EN GJL 250 (UNI EN 1561)

Pump housing

Cast iron EN GJL 250 (UNI EN 1561)

Bearing housing

Cast iron EN GJL 250 (UNI EN 1561)

Impeller

Cast iron EN GJL 250 (UNI EN 1561)

Mechanical seal motor side

Graphite/Ceramic

Mechanical seal impeller side

Silicon Carbide/Ceramic

Base frame

Hot-dipped galvanized steel

Motor shaft

Stainless steel AISI 420

Bolts and nuts

Stainless steel Grade A2

Cable

10 meters type NSSHÖU-J 10G2,5mm²

LIMITS TO USE

Max temperature of the liquid pumped

+40°C

pH of the liquid pumped

6÷10

Max immersion depth

20 m

Liquid density

1,0 kg/dm³

Min immersion depth for continuous service

635 mm

Free passage

100 mm

Max number starts/hour

15

Acoustic pressure level issued

<70dB(A)

MOTOR

The electric motor is asynchronous with squirrel cage rotor in dry chamber

Class of insulation F

Protection degree IP68

4pole; 50Hz

Main voltage values and relative tolerance in relation to the rated voltage value:

THREE-PHASE

400V ±10%

Other voltages on request.

OTHER FEATURES ON REQUEST

Frequency 60 Hz (*see specific catalogue*)

Other voltages

SECURITY

Thermal probes in the winding

Conductivity probe in the oil chamber

TECHNICAL DATA

MODEL	P1 kW	P2		VOLTAGE V	CURRENT A	CABLE m	WEIGHT kg
		kW	CV				
704/433	8,0	6,5	8,8	400/690 (3~)	14,5	10	156
1154/453	10,4	8,5	11,5	400/690 (3~)	18,5	10	163
1504/463	13,5	11,2	15,2	400/690 (3~)	23,5	10	174

F SERIES	704/433-1154/453-1504/463		DN 150
			50 Hz
			4 POLE

PERFORMANCE RANGE

CAPACITY														
<i>l/s</i>	0	15	20	30	40	45	50	55	60	65	70	80	90	100
<i>m³/h</i>	0	54	72	108	144	162	180	198	216	234	252	288	324	360
<i>l/min</i>	0	900	1200	1800	2400	2700	3000	3300	3600	3900	4200	4800	5400	6000

MODEL	CURVE N°	HEAD m													
		704/433	1	19,5	15,5	14,5	12,5	11,0	10,0	9,0	8,0	7,0	5,8	4,8	-
1154/453	2	24,0	18,5	17,5	16,0	14,0	13,5	12,5	11,5	10,5	9,5	8,3	6,0	3,5	-
1504/463	3	28,5	23,0	22,0	19,5	17,6	16,7	15,8	15,0	14,0	13,0	12,0	9,6	7,0	4,3

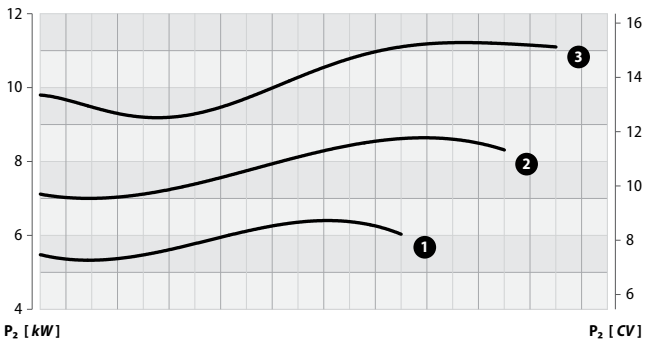
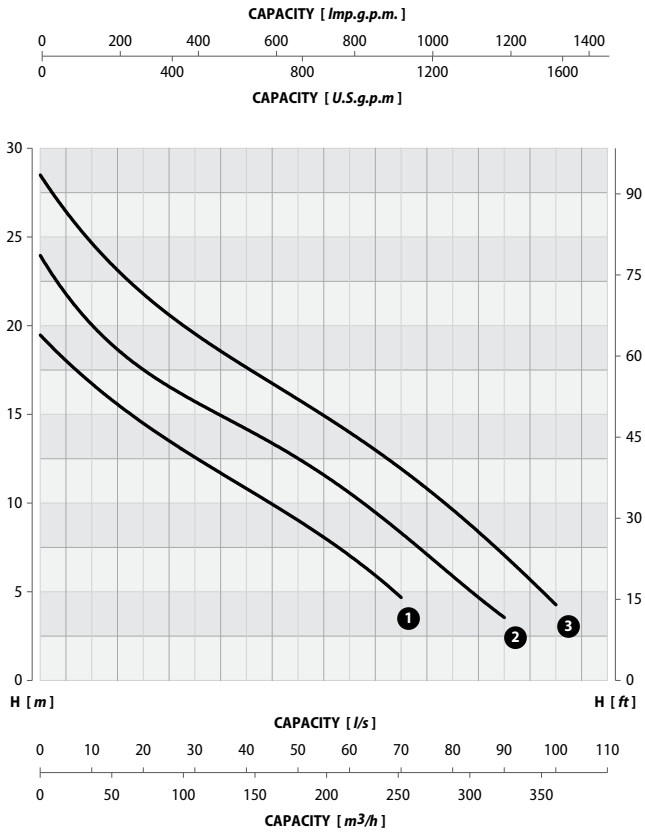

Performance tolerance in according to UNI/ISO 9906 Grade 2

F SERIES	704/433-1154/453-1504/463		SINGLE CHANNEL IMPELLER	DN 150
				50 Hz
				4 POLE

INSTALLATION DIMENSIONS

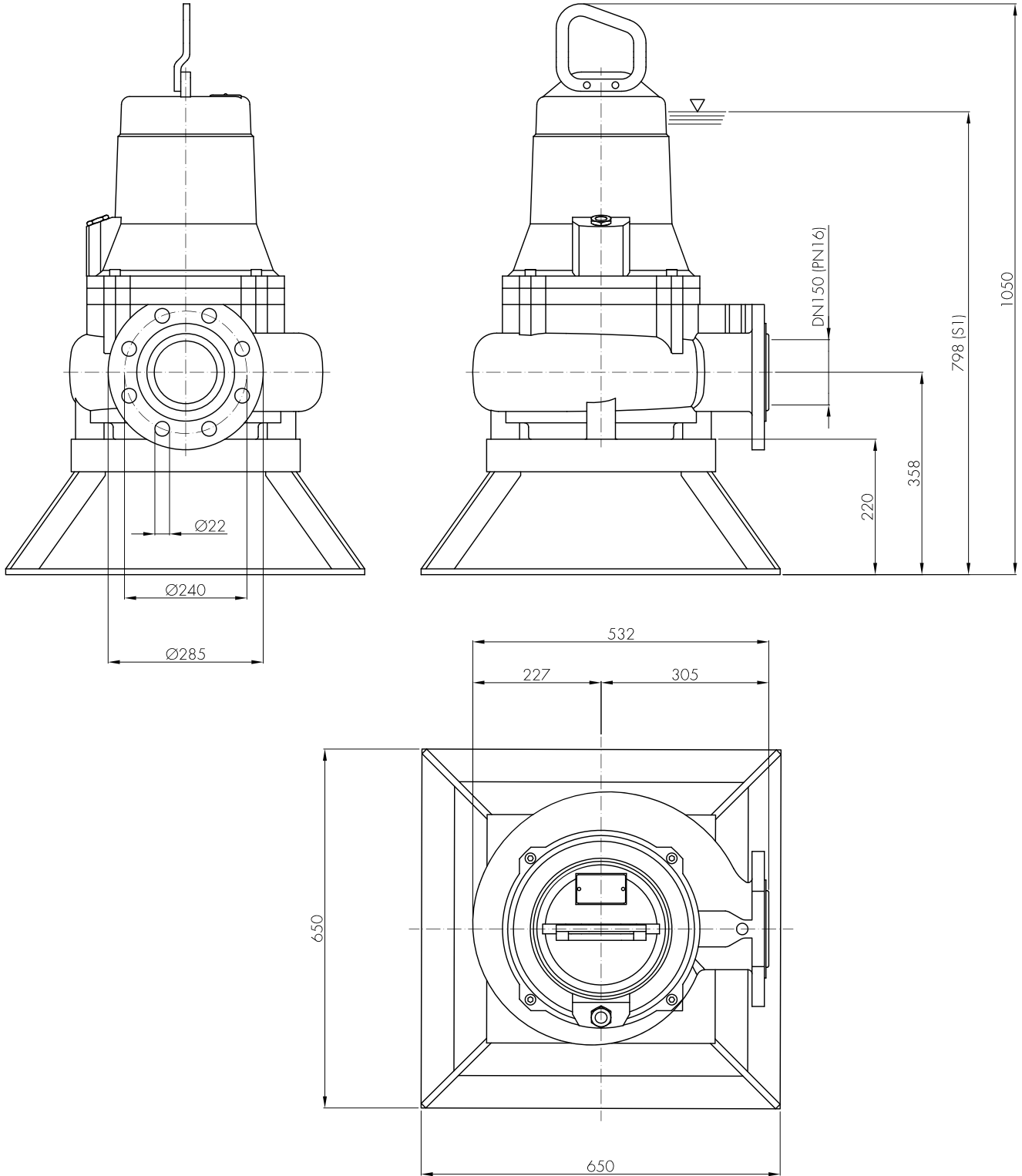

F SERIES	704/433-1154/453-1504/463		SINGLE CHANNEL IMPELLER
			DN 150
			50 Hz
			4 POLE

PERMANENT INSTALLATION WITH COUPLING SYSTEM

It is the recommended installation for the permanent pumping station. The electric pump is guided by two pipes and it is connected automatically to the coupling system. The quick connection ensures that the pump can be easily removed and re-installed.

PORTABLE INSTALLATION

Transportable as emergency pump with connection to the hose and for free installation in the well.

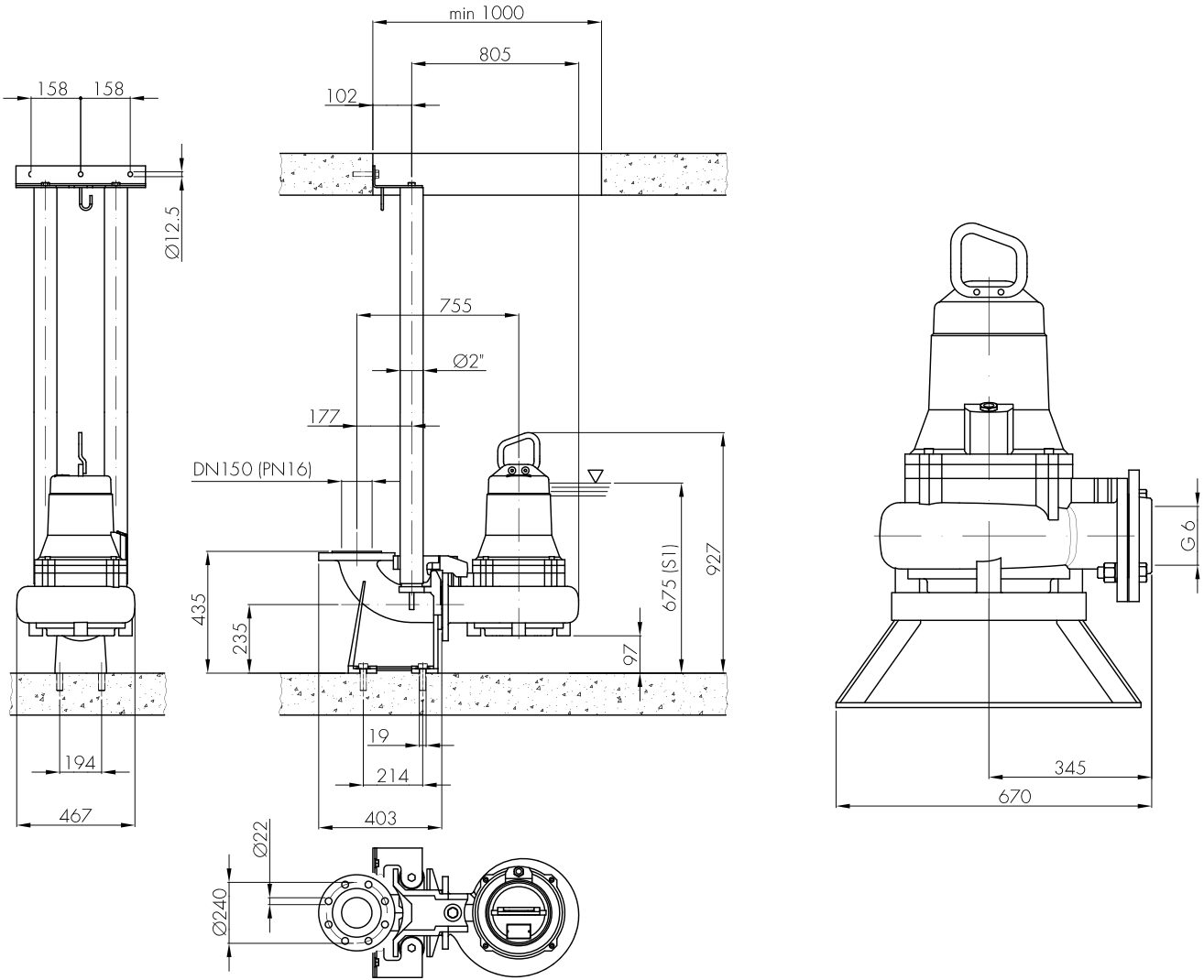

NOTES



.....

.....

.....

.....